

## OW

### DUAL FILTERS

FORM NO.: IM-OW-EN/Doc-09  
REVISION: Issue 28 Nov. 2016

ORIGINAL INSTRUCTIONS  
READ AND UNDERSTAND THIS MANUAL PRIOR TO OPERATING  
OR SERVICING THIS PRODUCT.

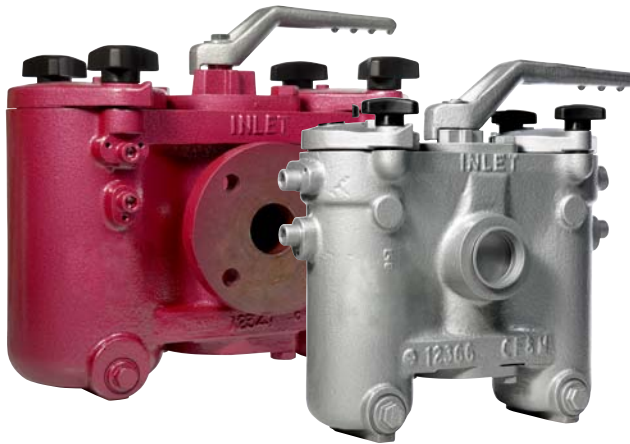

**Airpel Series**



# Contents

1.0	General .....	4
2.0	Installation .....	4
3.0	Specifications.....	5
4.0	Build Standards .....	6
5.0	Temperature Limitations.....	6
6.0	European Pressure Equipment Directive (97/23/EC) .....	6
7.0	Operation .....	6
8.0	Maintenance .....	7
9.0	Hazardous Fluids & Pressures .....	8
10.0	Pressure/Temperature Ratings.....	8
11.0	'O' seal temperature limits.....	8
12.0	Exploded view - Main components .....	9

## 1.0 General

OW dual filters are for use where uninterrupted flow is required, therefore the line does not need to be shut down to clean the basket. The filter consists of a diverter valve and two chambers containing the filter baskets; one on-line collecting debris and the other on stand-by. As the on-line basket becomes increasingly blocked with debris – the flow can be diverted, without interruption, to the stand-by (clean) basket by turning the handle through 180°. For safety reasons the handle always covers the on-line (pressurised) chamber. Basket cleaning is a quick and simple tool-free operation.

## 2.0 Installation

Installation and maintenance should be undertaken by a competent person. National and Local Codes of Practice, Environmental Regulations and Health and Safety Directives must be adhered to and take precedence over any stated or implied practices in this document. All OW filters are hydrostatically pressure tested prior to delivery.

Fit the filter assembly into the pipeline ensuring:

- There is no undue stress on the unit - support large filters appropriately.
- The unit is installed using suitable flange bolting materials and gaskets.
- The flow direction is correct.
- The unit is vertical with the cover at the top and the basket (element) is fitted.
- The unit is protected by suitable safety devices (pressure relief valves, earthing straps etc.) as appropriate within the system that it is installed.
- There is enough space available for maintenance operations.
- The fluid is compatible with the materials of construction. \*)
- The filter is being operated within its pressure/temperature performance envelope and within the flange drilling pressure/temperature limits. \*)
- The filter is clean, including (if appropriate) the removal of corrosion preventative liquids applied during manufacture.
- The cover(s), drain plug and any other attachments are secure.

Fill the filter with fluid, bleed air from the unit via the bleed screw(s), and check for leaks.

\*) See Doc-23 Chemical Compatibility and Doc-27 Pressure /Temperature Limits which are available on the Airpel Brand web site: [www.airpelfilters.com](http://www.airpelfilters.com).

### 3.0 Specifications

Model	OW/O	OW/WB	OW/S	OW/S A300	OW/S/WB	OW/C	OW/GM	OW/SS	OW/SS A300
<b>Body &amp; Cover</b>	Cast Iron EN1561 EN-JL 1030	Cast Iron EN1561 EN-JL 1030	Cast Steel EN10213-2 1.0625	Cast Steel EN10213-2 1.0625	Cast Steel EN10213-2 1.0625	Cast Iron EN1561 EN-JL 1030	Gunmetal (Bronze) BS1400 LG4C	St. Steel BS1504 316 C16	St. Steel BS1504 316 C16
<b>Sleeve</b>	-	Gunmetal (Bronze) BS1400 LG4C	-	-	Gunmetal (Bronze) BS1400 LG4C	-	-	-	-
<b>Changeover Cocks</b>	SG Iron EN1563 EN-JS 1020	Gunmetal (Bronze) BS1400 LG4C	SG Iron EN1563 EN-JS 1020	SG Iron EN1563 EN-JS 1020	Gunmetal (Bronze) BS1400 LG4C	St. Steel BS1504 316 C16	Gunmetal (Bronze) BS1400 LG4C	St. Steel BS1504 316 C16	St. Steel BS1504 316 C16
<b>Internal Components</b>	Mild Steel BS970 220 MO7	St. Steel BS970 303 S31	Mild Steel BS970 220 MO7	Mild Steel BS970 220 MO7	St. Steel BS970 303 S31	St. Steel BS970 303 S31	Phosphor Bronze BS1400 PB1	St. Steel BS970 303 S31	St. Steel BS970 303 S31
<b>Baskets</b>	Stainless Steel BS1449 316								
<b>Drain Plugs</b>	Brass	Brass	Stainless Steel	Stainless Steel	Brass	Stainless Steel	Phosphor Bronze	Stainless Steel	Stainless Steel
<b>Standard Seals</b>	Viton®	Viton®	Viton®	Viton®	Viton®	Viton®	Viton®	Viton®	Viton®
<b>Max Working Pressure</b>	17 bar at 50°C	17 bar at 50°C	22 bar at 50°C	50 bar at 50°C	22 bar at 50°C	17 bar at 50°C	17 bar at 50°C *)	22 bar at 50°C	48 bar at 50°C
<b>Body Colour</b>	Red	Blue	Silver	Silver	Silver	Blue	Natural	Natural	Natural

\*) Gunmetal (bronze) DN20, 25 and 40 filters are rated at 13.8 bar at 50°C  
Viton is a registered trademark of DuPont Performance Elastomers.

## 4.0 Build Standards

The OW range of filters is available in a number of formats to suit most applications.

The table shows the standard formats available and lists the materials of construction, maximum working pressure and the relevant colour code.

Other body, cover, seal and basket materials are available on request.

Cast Iron DN150 (6") multibasket OW filters are made from SG Iron (EN1563 EN-JS1020).

Cast Iron filter covers DN80 (3") and above are made from SG Iron (EN1563 EN-JS1020).

## 5.0 Temperature Limitations

The OW range of filters are limited to the following temperatures:

Filter Type	Max Working Temperature (°C)
OW/O, OW/S, OW/S A300, OW/GM, OW/SS, OW/SS A300	260
OW/WB, OW/S/WB	150
OW/C	50

All the above values are dependent on the limitations of the seal material.

## 6.0 European Pressure Equipment Directive (97/23/EC)

All cast OW filters comply with the European Pressure Equipment Directive (97/23/EC).

Where applicable, cast iron OW filters are to be restricted to Sound Engineering Practice applications only.

## 7.0 Operation

During normal operation the handle should be positioned over one chamber / side of the filter (see schematic diagram on the back page).

Intermediary positions of the handle are not recommended.

Flow is diverted from one chamber/side of the filter to the other by turning the handle through 180°.

The flow passes through the chamber/side that is covered by the handle.

The pressure drop across the basket(s) should not exceed 1.4 bar (20psi).

The basket(s) may incur damage if subjected to a pressure drop exceeding 2 bar (30psi).

If an optional Differential Pressure Indicator (DPI) with standard spring is fitted to monitor the pressure drop, the pointer moves from 'clean' (green) to 'dirty' (red) when the pressure drop is 0.7 bar (10 psi).

**To clean or inspect the basket(s) in the on-line chamber:**

- Equalise the pressure by opening the pressure equalising valve (if fitted).
- Divert the flow to the off-line chamber by turning the handle through 180° until it is hard against the stop.
- Close the pressure equalising valve (if fitted).  
Carefully relieve the pressure in the chamber to be cleaned.
- Once the pressure has been relieved – remove the drain plug and fibre washer and then slacken the cover nuts (hexagonal nuts on the DN150 & DN200 OW dual units) to drain the chamber of fluid (care should be taken with hazardous fluids).
- Swing the cover(s) open (remove the cover on the DN150 & DN200 OW dual units) to access the basket(s).
- Remove the basket(s) and carefully clean – inspect for damage and replace as necessary.
- Paper and other disposable elements cannot be cleaned and therefore should be replaced.
- Ensure that the 'O' seal sealing areas are clean.
- Refit the basket(s), cover(s) (ensuring that the 'O' seal is not damaged) and hand-tighten the cover nuts (hexagonal nuts on large sizes require a spanner) evenly to ensure the cover(s) seal.
- Refit the drain plug and fibre washer.
- Bleed air from the off-duty chamber by releasing the bleed screw in the cover(s) until all air is eliminated – then tighten the bleed screw.
- The flow can now be diverted back through the filter chamber as required.

**Notes**

- 1 If the filter is fitted with a pressure equalising valve – the valve must be opened before turning the handle and closed immediately after the handle has reached it's limit of motion.
- 2 Under normal operation – the standard design (not the positive seal option), allows a small amount of fluid to bypass between the on-line and the stand-by chambers. This is a design feature that eliminates the requirement of a pressure equalising system on smaller filters.
- 3 The positive seal option utilises a special seal set into the cocks (valves). This reduces any fluid bypass to a negligible level. After cleaning the basket it is important to bleed air from the stand-by chamber by opening the pressure equalising valve and releasing the bleed screw in the cover(s). Once all air has been eliminated – tighten the bleed screw and close the pressure equalising valve.
- 4 SPX FLOW recommend the fitting of valves to the drain connections for ease of use and increased operator safety.

## 8.0 Maintenance

The OW dual filters require very little routine maintenance.

Regularly check the condition of 'O' seals and sealing surfaces – replace and / or clean as necessary.

Regularly check the condition of the baskets (particularly the fine mesh if appropriate) for damage and replace as necessary.

Periodically inspect the filter assembly for corrosion and other deterioration that may affect the integrity of the vessel.

We recommend that the changeover handle is operated back and forth a minimum of once per day (to prevent seizure). Frequency of basket cleaning remains process dependant.

Description	Interval (every)	Remarks
Visual inspection, external	Week	
Inspection of Filter/internals for damage	6-9 Months	Each time Filter is opened
Clean and Lubricate: Cover Nuts & Studs, Cock spindle, Upper & Lower Cock	Year	General Purpose Grease

Re: General Purpose Grease: Use a good general purpose grease such as Castrol Spherol LMM or BP Energrease Universal

## 9.0 Hazardous Fluids & Pressures

- The filters, when despatched from SPX FLOW, do not contain substances specifically hazardous to health, but may have a thin coating of oil based corrosion preventative on all internal surfaces.
- If the fluid to be filtered is in any way hazardous, the operator and the environment should be suitably protected. Care should be exercised if the fluid at atmospheric conditions is above its boiling point.
- Relieve the pressure in the filter before opening the filter cover.
- Do not make any adjustments whilst the filter is pressurised.
- If a filter is to be stored or transported, ensure that the filter is clean, suitably protected (including corrosion protection if appropriate) and does not contain substances that could be hazardous to health.

## 10.0 Pressure/Temperature Ratings

The filter should be used within the flange drilling pressure/temperature limits and the filter body limits. Discuss higher temperature pressure ratings with SPX FLOW \*).

Filter Material	Standard Range	A300 Range
Cast Iron	17 bar at 50°C	Not available
Cast Steel	22 bar at 50°C	50 bar at 50°C
Stainless Steel	22 bar at 50°C	48 bar at 50°C
Gunmetal (bronze)	17 bar at 50°C	Not available

Gunmetal (bronze) DN20, 25 & 40 filters are rated at 13.8 bar at 50°C.

All pressures are non-shock.

\*) See Doc-23 Chemical Compatibility and Doc-27 Pressure /Temperature Limits which are available on the Airpel Brand web site: [www.airpelfilters.com](http://www.airpelfilters.com).



## 11.0 'O' seal temperature limits

Viton®:	-20°C to +200°C	PTFE encapsulated Viton:	-20°C to +200°C
Ethylene propylene:	-50°C to +150°C	PTFE encapsulated silicone:	-55°C to +260°C

The above values are guidelines based upon absolute compatibility with the fluid and are not binding due to unaccountable factors that may be detrimental to the performance of the 'O' seals.

**Note:** *As SPX FLOW has no control over the use or operating conditions we cannot be held responsible for any damage to/by the filter, or any subsequent costs incurred. It is essential that the user satisfies himself of the suitability of the equipment for the intended application*

## 12.0 Exploded view - Main components

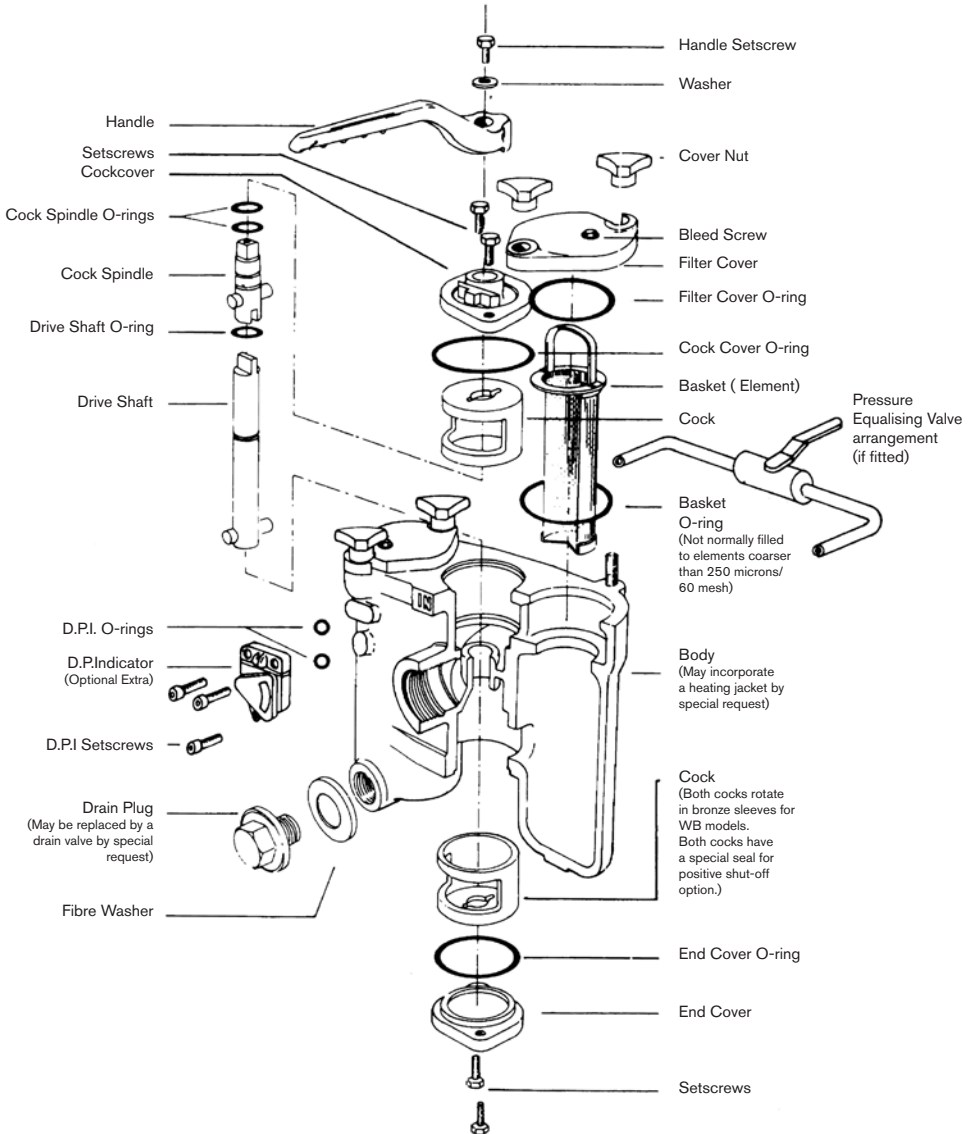

**Seal Kit contains:**

Cover O-Rings	} Nitrile, Viton®, EP or Viton Encapsulated PTFE to suit requirement
Basket O-Rings	
Cock Spindle O-Rings	
Drive Shaft O-Rings	
Bleed Screw Washer	
Drain Plug Washer	

O-Rings and Washers only available in Seal Kit

**Schematic Indicating Function for different Handle Positions**

**150 mm (6 inch) - Multi basket Filter Arrangement**

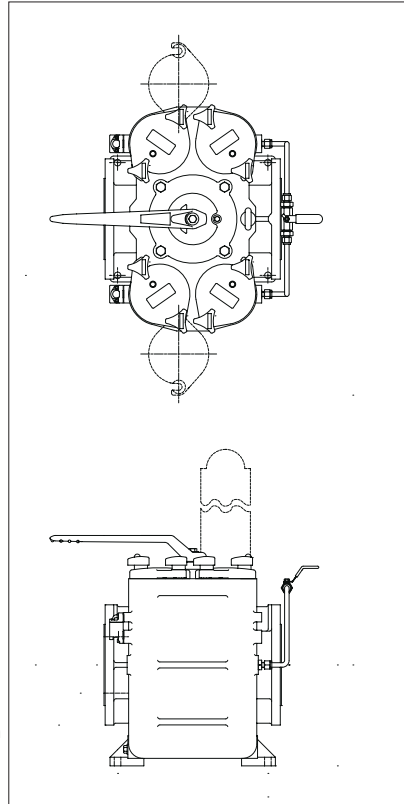
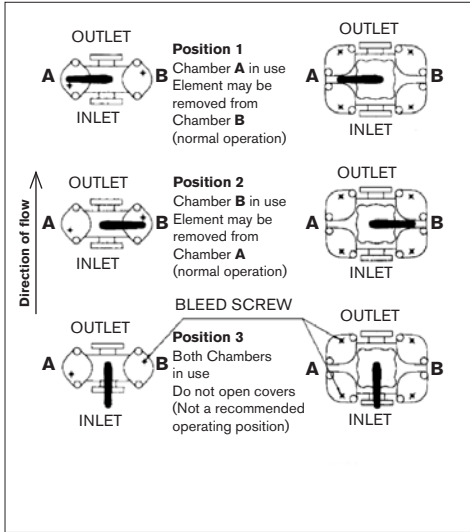

**Notes**

- 1 All filters have 1/2" drain plugs.
- 2 Filters with threaded inlet/outlet ports can be either NPT or BSP threads.
- 3 The drain port can be threaded NPT or BSP.
- 4 When ordering spares please define (as appropriate):
  - Filter size and body material.
  - Seal kit material (e.g. Viton® or EPDM).
  - Basket mesh size.

An Differential Pressure Indicator (DPI) may be fitted to indicate when the basket needs cleaning.

The illustrations shown are not binding. The right to change specification without notice is reserved.

OW

DUAL FILTER

**SPXFLOW**

**SPX Flow Technology**

Hambridge Road  
Newbury, Berkshire, RG14 5TR, UNITED KINGDOM  
Phone: +44 (0) 1635 263915  
Fax: +44 (0) 1635 36006  
E-mail: [airpel@spxflow.com](mailto:airpel@spxflow.com)

For more information about our worldwide locations, approvals, certifications, and local representatives, please visit [www.spxflow/en/airpel.com](http://www.spxflow/en/airpel.com). SPX FLOW, Inc. reserves the right to incorporate our latest design and material changes without notice or obligation. Design features, materials of construction and dimensional data, as described in this bulletin, are provided for your information only and should not be relied upon unless confirmed in writing.

ISSUED 11 / 2016 IM-OW-EN/Doc-09  
COPYRIGHT ©2016 SPX FLOW, Inc.