

M&J VALVE

AN SPX BRAND

Technical Bulletin

Swing Check Valve



SPX[®]

Table of Contents

General Description	3
Design Features	
Sealing Features.....	4
NDE Specifications	5
Recommended Spare Parts	6
Service	5
Warranty	5
Standard Product.....	5
Trim Charts	
Figure Number Key	7
Trim Definitions.....	7
Drawings	
Exploded View.....	8
Dimensional Data	9
Weight Data.....	9
Assembly	10
Engineering Data	
Flow Data	11
Conversion Data.....	12

M&J Valve
19191 Hempstead Highway
Houston, TX 77065

Telephone: 281-469-0550
Fax: 281-894-1332

E-Mail: mjvalve@spx.com
Web Site: www.mandjvalve.com

SPX reserves the right to incorporate our latest design and material changes without notice or obligation. Design features, materials of construction and dimensional data, as described in this bulletin, are provided for your information only and should not be relied upon unless confirmed in writing. Certified drawings are available upon request.

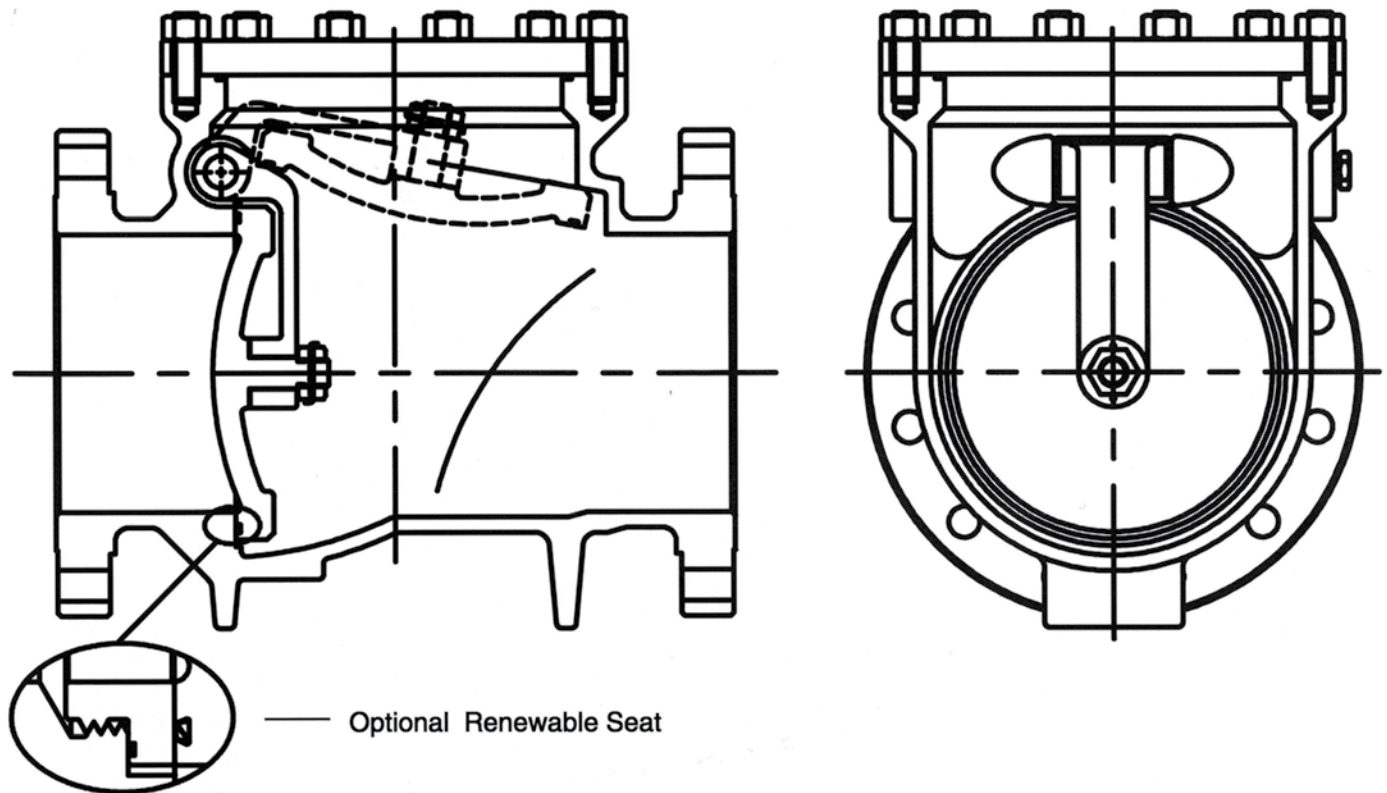

GENERAL DESCRIPTION

The M&J Swing Check Valve design is based on many years of field use, engineering expertise and the latest state-of-the-art technology. This combined with M&J Valve's history of customer service, "after the sale" support and comprehensive quality assurance program, ensures a product meeting the highest standards. The M&J Swing Check Valve is produced in an environment conforming to API-Q1 and ISO-9001 and designed, manufactured, tested and certified to one or more of the following: API-6D, ANSI B16.5, ANSI B16.10, ANSI B16.34, ANSI B2.1, API-598, API-1104, BS EN 12627:1999, BS EN 558-1:1996, BS EN 558-2:19, BS 6755-1:1986, BS 6755-2:1987, BS 6755-1:1986, BS 6755-2:1987, BS EN 12266-1:2003, BS EN 12266-2:2002, BS EN ISO 10497:2004.

The Swing Check Valve is a one-piece body, top entry design for reliable operation and extended seat seal life. Top entry construction allows field service and in-line maintenance if necessary.

All major components of the check valve are normally made from cast and wrought forms, allowing the use of a variety of widely accepted materials.

M&J Swing Check Valves are full bore. The full bore to API-6D assures unrestricted flow and allows pigging and hot tapping.

DESIGN FEATUTES

The M&J Swing Check Valve is a robust design which incorporates all of the desirable features proven to provide long life and trouble free operation. Backflow prevention is assured by the free swinging clapper design which responds to the changes in flow and provides positive closure prior to the reversal of flow. The valve can be installed in horizontal or vertical flow-up applications without external closure assistance, i.e. counterweights.

Clapper Seals – the clapper/arm design of the Swing Check Valve provides positive alignment between the clapper face and the seat face in the body. Primary sealing is assured by the metal-to-metal contact between these faces. Secondary sealing is provided by a non-metallic insert in the clapper face (fig 1).

Extended Shaft Sealing – for applications requiring extended shaft, the Swing Check Valve design incorporates a bolted stem housing with dual seals, (fig 2) on the shaft to provide positive sealing. In addition, the design has a unique key/clutch attachment of the shaft to the clapper arm which allows (except in retarder applications) the clapper/arm to swing freely in response to flow while the shaft remains stationary, reducing wear on the shaft seals.

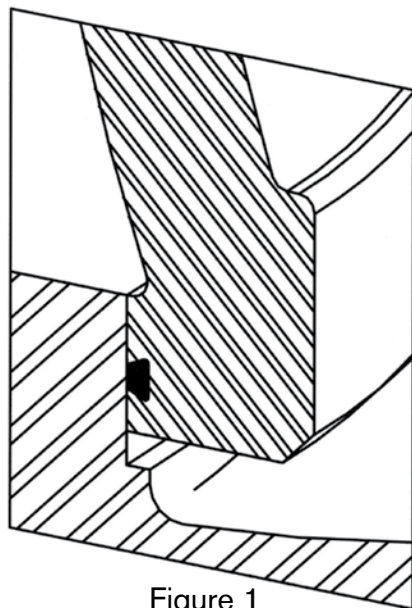

Figure 1

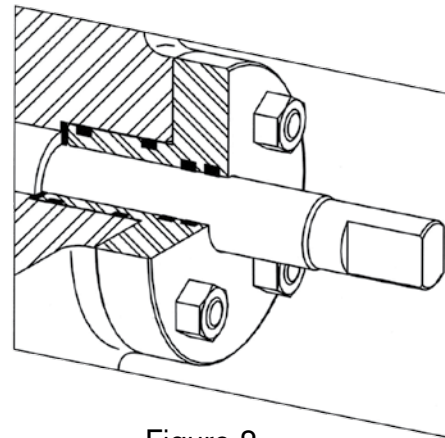

Figure 2

EXTENDED SHAFT APPLICATIONS

Clapper lock-open – Some check valve applications require the ability to lock the valve clapper open. These applications may be: to allow back flow for depressurization flushing or prevention of isolation of pipe line section during test; for critical pigging operations such as intelligent pigging or where pressure and/or flow rates used are very low. The Swing Check Valve cannot be locked closed.

Counterweight – A counterweight is normally specified on the following check valve application: in vertical flow down to insure clapper closure in, low flow conditions to counterbalance clapper weight and reduce pressure loss; critical flow conditions where reduced closure time is provided by the counterweight assisting closure.

Retarder – The hydraulic retarder is normally used in gas flow application where the flow rate fluctuates and can allow the clapper to close frequently during normal operation. The retarder stabilizes clapper movement. A retarder should not be used in liquid flow pipelines because it may allow the commencement of reverse flow and the resultant “water hammer”.

Other – There are many other special applications of the extended shaft feature such as: spring return clapper; emergency close controlled by electric solenoid or fusible link flow indication, etc.

**TYPICAL SPECIFICATIONS FOR
NON-DESTRUCTIVE
TESTING/EXAMINATION**

(Available as required)

Description of Test	Applicable Standards
Dye Penetrant	ASME V - Art 6 and 21 ASTM E165 ANSI B16.34 - Annex D
Magnetic Particles (wet or dry)	ASME V - Art 7 and 25 ASTM E709 ANSI B16.34 - Annex C
Radiography	API - 1104 ASME V - Art 2 and 22 ASME VIII - Div 1 ANSI B16.34 - Annex B ASTM E142, E94, E446, E186, E280
Ultrasonic	ASME V - Art 4 and 23 ASTM VII - Div 1 ASTM A388
Hydrostatic and Pneumatic	API - 598, API - 6D BS - 5146 and 6755 MSS-SP61 Customer's Specifications
Stem Torque	API - 6D Customer's Specifications
Visual and Dimensional	BS 2080 ANSI B16.34, B16.5, B16.10 MSS-SP44 and SP55
Material Hardness	NACE MR - 01-75 (Latest edition)

Other non-destructive or destructive testing may be conducted to meet customer requirements and/or specifications.

Please contact your local M&J Valve representative for additional information.

Feature		Standard	When Specified
API-6D/Q1		X	
ISO 9001		X	
Lock-open			X
Transition Pieces (Pups)			X
Hydraulic Dampener			X
Counter Balance			X
Body Plug		X	
Body Drain			X
Body Lift Lugs		X	
Body Footing		X	
Subsea			X
Removable Seat			X
API Monogram			X
API-6D Test:	Hydro Shell	X	
	Hydro-Seat	X	
	Air Seat		X
	Operational Torque Test		X
	Extended Hydro Test		X
NDE:	Visual (API 6D)	X	
	Ultrasonic		X
	Dye Penetrant		X
	Magnetic Particle		X
	Radiography		X
Documentation/ Certification:	Hydrotest Reports		X
	Material Test Reports (MTRS)		X
	Hydrotest Charts		X
	NDE Reports		X
	Nace		X
	Certificate of Compliance		X
	Operational Test Reports		X

RECOMMENDED SPARE PARTS

It is recommended that the following spare parts be inventoried in operations having numerous valves of a given size and an in-house maintenance program.

Part Description	Number of Valves to be Supported			
	< 10	11-20	21-30	31-40
Arm	0	1	2	3
Clapper	0	2	4	6
Shaft	0	1	2	3
O-Rings, Set	1	2	3	4

SERVICE

Every product sold by M&J Valve is supported by our full technical staff. This staff is available to provide you with technical advice, backup documentation, spare parts and repair services, either in the plant or in the field. Our well-trained and experienced field service staff stands ready to support you and our products around the world.

WARRANTY

The Company warrants all equipment manufactured by it to be free from defects in workmanship and material provided that such equipment was properly selected for the service intended, properly installed, and not misused. Equipment which is returned transportation prepaid to the Company's originating factory within 12 months after installation, or 18 months from delivery of equipment, for destination outside the United States, and if found by the Company's inspection to be defective in workmanship or material will be repaired or replaced, at the Company's option, free of charge and return-shipped lowest cost transportation prepaid. WITH EXCEPTION OF THE WARRANTY SET FORTH ABOVE, THE COMPANY MAKES NO EXPRESS OR IMPLIED WARRANTIES, NO WARRANTY OF MERCHANTABILITY, NO WARRANTY OF FITNESS FOR PURPOSE, AND NO OTHER WARRANTIES WHICH EXTEND BEYOND THE DESCRIPTION ON THE FACE HEREOF.

Swing Check Valve Figure Number Key

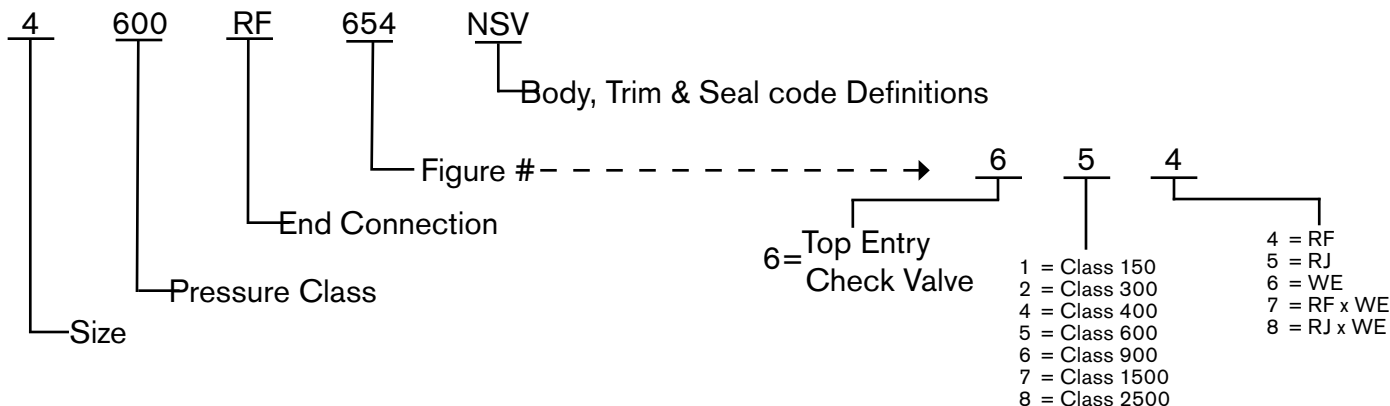

Standard Trim Definitions

Body Trim Definitions

Item	Trim	Standard Carbon Steel	N Carbon Steel/ NACE	S Full Stainless	L Low Temp. -50 °F	LN Low Temp. -50 °F/NACE
B1	Body	ASTM A216 WCC	ASTM A216 WCC	ASTM A351 CF8M	ASTM A352 WCC	ASTM A352 WCC
B2	Cover	ASTM A36	ASTM A36	ASTM A240 316	ASTM A537 CL2	ASTM A537 CL2
B3	Shaft Plug (Standard)	ASTM A105	ASTM A105	ASTM A276 316	ASTM A276 316	ASTM A276 316
	Shaft Gland (Extended Shaft)	AISI 1018/1020	AISI 1018/1020	ASTM A276 316	ASTM A276 316	ASTM A276 316
B4	Stud	ASTM A193 B7	ASTM A193 B7M	ASTM A193 B7 FLRCTD	ASTM A320 L7	ASTM A320 L7M
B5	Nut	ASTM A194 2H	ASTM A194 2HM	ASTM A194 2H FLRCTD	ASTM A194 GR7	ASTM A194 GR7M
B6	Vent Plug	ASTM A105	ASTM A105	ASTM A276 316	ASTM A276 316	ASTM A276 316

Internals Trim Definitions

Item	Trim	Standard Carbon Steel	O 316L Overlay	S Full Stainless	H Hardfaced	E Electroless Nickel
T1	Arm	ASTM A216 WCC	ASTM A216 WCC	ASTM A351 CF8M	ASTM A216 WCC	ASTM A216 WCC
T2	Shaft (Standard)	ASTM A270 316	ASTM A270 316	ASTM A240 316	ASTM A270 316	ASTM A270 316
	Shaft (Extended)	ASTM B630 17-4PH Double H1150	ASTM B630 17-4PH Double H1150	ASTM B630 17-4PH Double H1150	ASTM B630 17-4PH Double H1150	ASTM B630 17-4PH Double H1150
T3	Clapper	ASTM A216 WCC	ASTM A216 W/316 Overlay	ASTM A351 CF8M	ASTM A216 W/HF Overlay	ASTM A216 WCC W/.003 ENP
T4	Nut (Clapper)	ASTM A194 2M	ASTM A194 2HM	ASTM A194 B8M	ASTM A194 2HM	ASTM A194 2M
T5	Pin	316 SS	316 SS	316 SS	316 SS	316 SS
T6	Spacer	18-8 SS	18-8 SS	18-8 SS	18-8 SS	18-8 SS
T7	Seat	Integral	ASTM A216 WCC W/316L Overlay	ASTM A351 CF8M	ASTM A216 WCC W/HF Overlay	ASTM A216 WCC
		Renewable	AISI 1018/1020	ASTM A270 316	ASTM A270 316 W/HF Overlay	ASTM A270/A240 316
T8	Key (Extended Shaft)	316 SS	316 SS	316 SS	316 SS	316 SS

Seals Trim Definitions

Item	Trim	Standard	V Fluoroelastomer	N Neoprene	D Danseal	MR Metal-to-Metal
S1	Clapper Seal	Nitrile	Viton	Neoprene	Danseal	Metal-to-Metal
S2	Cover Seal	Nitrile	Viton	Neoprene	Danseal	RTJ Gasket
S3	Seat Seal (Renewable Seat)	Nitrile	Viton	Neoprene	Danseal	Graphoil
S4	Gland Seal (Extended Shaft)	Nitrile	Viton	Neoprene	Danseal	Graphoil
S5	Shaft Seal (Extended Shaft)	Nitrile	Viton	Neoprene	Danseal	Graphoil

The materials listed above are not to be considered a limit to the availability of other materials/trim. Other materials/trims can be furnished on application.

Swing Check Valve Exploded View

4" and smaller

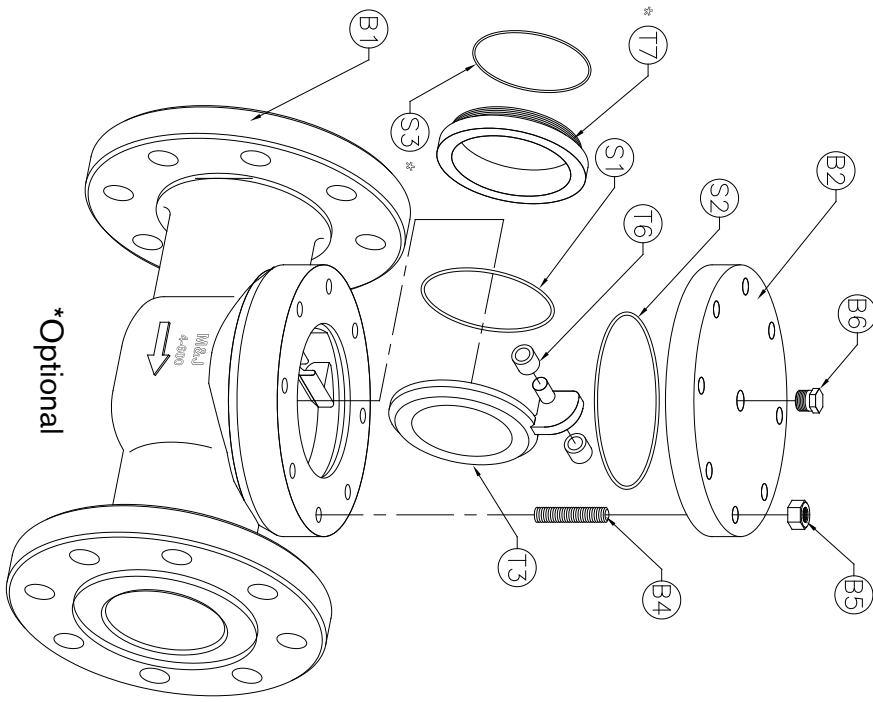

6" and larger

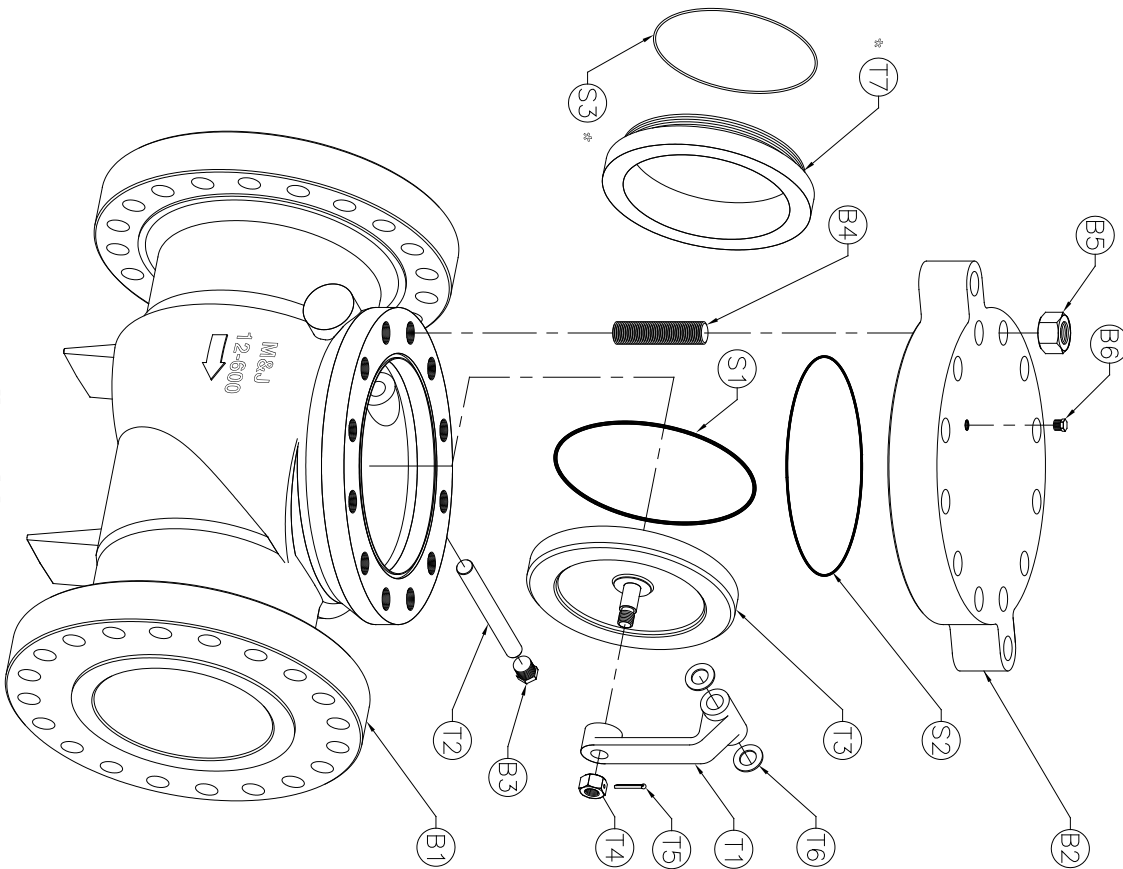

Swing Check Valve Dimensional Data

Valve Size (in)	ANSI	A In(mm)			B In(mm)	C In(mm)	Wt. (lbs)
		RF	WE	RTJ			
2	150	8.00 (203)	8.00 (203)	8.50 (216)	3.00 (76)	4.75 (121)	35
	300	10.50 (267)	10.50 (267)	11.13 (283)	3.25 (83)	4.75 (121)	42
	600	11.50 (292)	11.50 (292)	11.63 (295)	3.25 (83)	4.75 (121)	45
	900	14.50 (368)	14.50 (368)	14.63 (372)	4.25 (108)	7.25 (184)	150
3	150	9.50 (241)	9.50 (241)	10.00 (254)	3.75 (95)	5.31 (135)	70
	300	12.50 (318)	12.50 (318)	13.13 (334)	4.13 (105)	5.31 (135)	70
	600	15.00 (381)	15.00 (381)	14.13 (359)	4.13 (105)	5.31 (135)	75
	900	15.00 (381)	15.00 (381)	15.13 (384)	4.75 (121)	7.44 (189)	180
4	150	11.50 (292)	11.50 (292)	12.00 (305)	4.50 (114)	5.88 (149)	80
	300	14.00 (356)	14.00 (356)	14.63 (372)	5.00 (127)	5.88 (149)	120
	600	17.00 (432)	17.00 (432)	17.13 (435)	5.38 (137)	6.13 (156)	140
	900	18.00 (457)	18.00 (457)	18.13 (461)	5.75 (146)	8.19 (208)	250
6	150	14.00 (356)	14.00 (356)	14.50 (368)	5.75 (146)	7.94 (202)	160
	300	17.50 (445)	17.50 (445)	18.13 (461)	6.50 (165)	8.44 (214)	220
	600	22.00 (559)	22.00 (559)	22.13 (562)	7.06 (179)	8.69 (221)	360
	900	24.00 (610)	24.00 (610)	24.13 (613)	7.69 (195)	9.31 (236)	420
8	150	19.50 (495)	19.50 (495)	20.00 (508)	7.19 (183)	9.56 (243)	300
	300	21.00 (533)	21.00 (533)	21.63 (549)	7.94 (202)	10.06 (256)	340
	600	26.00 (660)	26.00 (660)	26.13 (664)	8.69 (221)	10.56 (268)	600
	900	29.00 (737)	29.00 (737)	29.13 (740)	9.69 (246)	11.06 (281)	760
10	150	24.50 (622)	24.50 (622)	25.00 (635)	9.19 (233)	12.44 (316)	630
	300	24.50 (622)	24.50 (622)	25.13 (638)	9.19 (233)	12.82 (326)	790
	600	31.00 (787)	31.00 (787)	31.13 (791)	10.25 (260)	13.56 (344)	970
	900	33.00 (838)	33.00 (838)	33.13 (841)	11.19 (284)	14.06 (357)	1160
12	150	27.50 (699)	27.50 (699)	28.00 (711)	10.75 (273)	13.50 (343)	970
	300	28.00 (711)	28.00 (711)	28.63 (727)	10.75 (273)	14.00 (356)	1100
	600	33.00 (838)	33.00 (838)	33.13 (841)	11.13 (283)	14.75 (375)	1450
	900	38.00 (965)	38.00 (965)	38.13 (968)	12.19 (310)	15.56 (395)	1890
16	150	34.00 (864)	34.00 (864)	34.50 (876)	13.00 (330)	18.69 (475)	1680
	300	34.00 (864)	34.00 (864)	34.63 (879)	13.38 (340)	19.44 (494)	2210
	600	39.00 (991)	39.00 (991)	39.13 (994)	13.75 (349)	20.44 (519)	2520
	900	44.50 (1130)	44.50 (1130)	44.88 (1140)	14.06 (357)	21.19 (538)	2840
20	150	38.50 (978)	38.50 (978)	39.00 (991)	15.75 (400)	22.00 (559)	2100
	300	40.00 (1016)	40.00 (1016)	40.75 (1035)	15.75 (400)	22.88 (581)	2580
	600	47.00 (1194)	47.00 (1194)	47.25 (1200)	16.50 (419)	24.00 (610)	4000
	900	52.00 (1321)	52.00 (1321)	52.50 (1334)	17.38 (441)	25.25 (641)	4200
24	150	51.00 (1295)	51.00 (1295)	51.50 (1308)	18.50 (470)	26.88 (683)	3530
	300	53.00 (1346)	53.00 (1346)	53.88 (1368)	18.50 (470)	27.88 (708)	4200
	600	55.00 (1397)	55.00 (1397)	55.38 (1407)	19.00 (483)	29.50 (743)	5520
	900	61.00 (1549)	61.00 (1549)	61.75 (1568)	19.00 (483)	30.50 (775)	8420

Swing Check Valve Dimensional Assembly

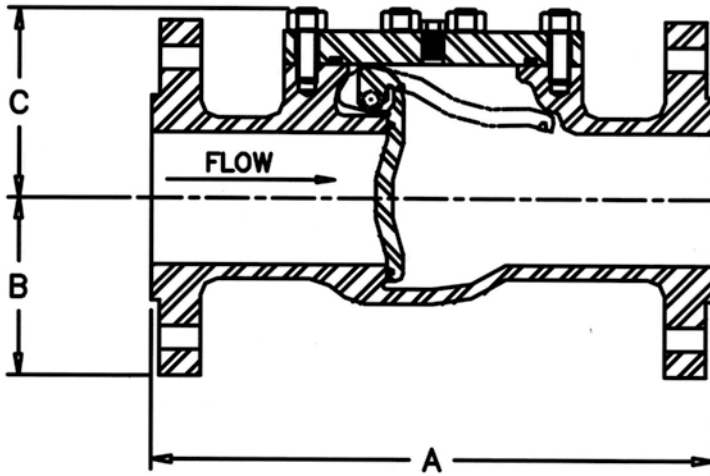

4" and Smaller

Flanges

Sizes 2" through 24"... ANSI B16.5
Sizes 26" through 36"... MSS-SP-44

Weld Ends

Per ANSI B31.4

Face to Face and End to End
Dimensions conform to API-6D,
Table 4.4

Full Bore per API-6D
Table 4.0

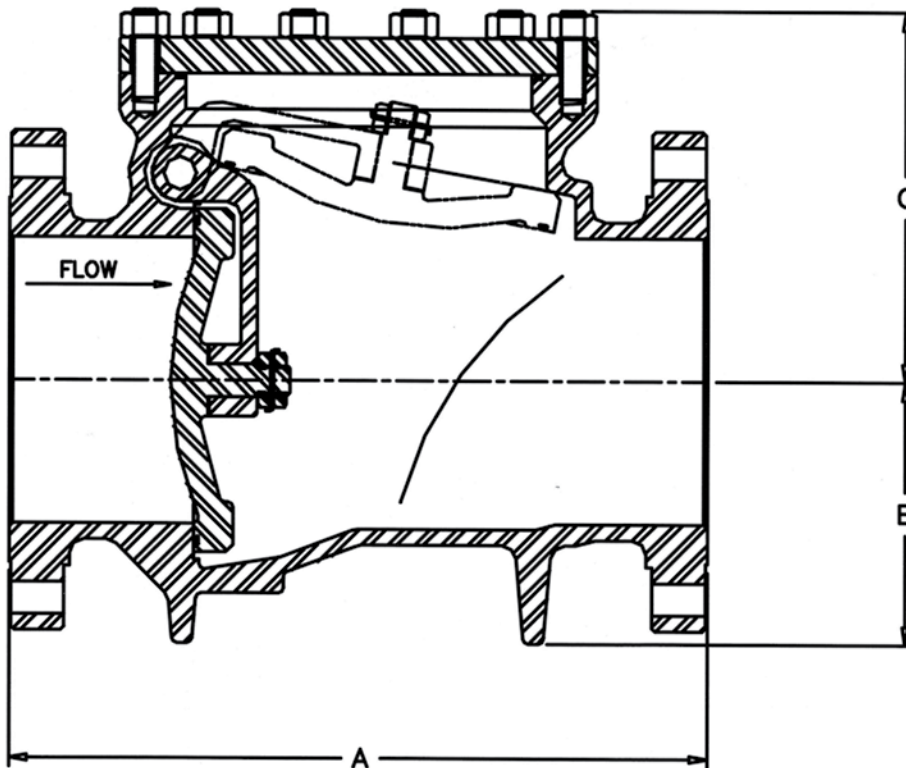

6" and Larger

Flow Coefficient Equations

For Liquids:

$$Q = C_v \sqrt{\frac{\Delta P}{G}}$$

Q = Flow, Gallons per minute
 C_v = Flow Coefficient
 ΔP = Pressure Drop, psi
 G = Specific Gravity (Water = 1)

For Gases:

$$Q = 963 C_v \sqrt{\frac{P_1^2 - P_2^2}{GT}}$$

Q = Flow, Gallons per minute
 C_v = Flow Coefficient
 P₁ = Upstream Pressure, psia
 P₂ = Downstream Pressure, psia
 T = Absolute Temperature (°F + 460)
 G = Specific Gravity (Air = 1)

Flow Coefficients (C_v)

Flow coefficient, or C_v, by definition is the volume of water in gallons per minute at 60°F that will flow through a given element with a pressure drop of 1 psi.

SIZE	C _v
2	106
3	238
4	424
6	954
8	1696
10	2650
12	3816
14	4652
16	6163
18	7885
20	9819
24	14324

Hydraulic Constants and Conversions

Volume and Density

1 Barrel = 42 (US) gallons=5.6145 cubic feet=702 cubic inches
 1 Barrel = 0.1590 cubic meters=159 liters
 1 Gallon (US) = 0.1337 cubic foot=231 cubic inches=0.833 gallons (IMP)
 1 Gallon (MP) = 1.20 gallons (US)=0.1604 cubic inches=277.2 cubic inches
 1 Gallon (US) = 3.785 liter=0.003785 cubic meters
 1 Cubic Foot = 7.4805 gallons (US)=6.231 gallons (IMP)=0.1781 Barrels
 1 Cubic Foot = 0.028317 cubic meters=28.317 liters
 1 Cubic Meter = 6.29 barrels

Rates of Flow

Gallon per minute = 0.02918 x Barrels/day
 Gallons per day = 1,008 x Barrels/hour

Velocity in Pipes

Feet per second = ft³/hr x 0.509 ÷ (inch ID)²
 Feet per second = bbl/hr x 0.2859 ÷ (inch ID)²
 Feet per second = gallon (US)/min x 0.4085 ÷ (inch ID)²
 Meters per second = M³/hr x 353.68 ÷ (inch ID)²

Contents of Pipelines

Gallons (US) per 1000 ft = 42 (US) gallons=5.6145 cubic feet=702 cubic inches
 Barrels per 1000 ft = 0.1590 cubic meters=159 liters
 Gallons (US) per mile = 0.1337 cubic foot=231 cubic inches=0.833 gallons (IMP)
 Barrels per mile = 1.20 gallons (US)=0.1604 cubic inches=277.2 cubic inches
 Cubic meter per Kilometer = 0.0007854 x (mmID)²

Engineering Conversion Factors

Multiply	By	To Obtain
Atmosheres	29.92	Inches of Mercury
"	33.90	Feet of Water
"	1.033	Kgs./sq. cm.
"	14.70	Lbs./sq. inch
Barrels-Oil	42	Gallons-oil
Bar	14.504	Lbs./sq. inch
"	100,000	Pascal
Cubic Feet	1728	Cubic Inches
"	0.02832	Cubic Meters
"	7.48052	Gallons
Cubic Feet/minute	0.1247	Gallons/second
Cubic Feet/second	0.646317	Million Gallons/day
"	448.831	Gallons/minute
Cubic Inches	5.787×10^{-4}	Cubic Feet
"	1.639×10^{-5}	Cubic Meters
"	2.1413×10^{-5}	Cubic Yards
"	4.329×10^{-3}	Gallons
Cubic Meter	35.31	Cubic Feet
"	61,023	Cubic Inches
"	264.2	Gallons
"	103	Liters
Feet of Water	1.02950	Atmosphere
"	0.8826	Inches of Mercury
"	0.0305	Kgs./sq.cm.
"	62.43	Lbs./sq.ft.
"	0.4335	Lbs./sq. inch
Foot-Pound	1.356	Newton-Meter
Feet/minute	0.01667	Feet/sec.
"	0.01829	Kilometer/hour
"	0.3048	Meters/minute
"	0.01136	Miles/hour
Feet/second	1.097	Kilometers/hour
"	18.29	Meters/minute
"	0.6818	Miles/hour
Gallons	0.1337	Cubic feet
"	231	Cubic inches
"	3.78×10^{-3}	Cubic meters
Gallons, Imperial	1.20095	U.S. Gallons
Gallon, U.S.	0.83267	Imperial Gallons
Gallons water	8.3453	Pounds of water
Gallons/min	2.228×10^{-3}	Cubic feet/second
"	8.0208	Cu. ft./hour
"	1.459	Barrels/hour

Multiply	By	To Obtain
Inches	25.4	Millimeters
Inch-Pound	.113	Newton-Meter
Inches of Mercury	0.03342	Atmosphere
"	1.133	Feet of water
"	0.0345	Kgs./sq.ft.
"	70.73	Lbs./sq. ft.
"	0.4912	Lbs. sq. inch
Inches of Water	0.002458	Atmosphere
"	0.07355	Inches of mercury
"	0.0025	Kgs./sq.cm.
"	5.202	Lbs./sq.foot
"	0.03613	Lbs./sq. inch
Kilograms	980,665	Dynes
"	2,205	Lbs.
Meters	3.2181	Feet
"	0.05468	Inches
"	39.97	Kilometers
"	10^{-3}	Millimeters
Meters/minute	3.281	Feet/minute
"	0.05468	Feet/second
"	0.06	Kilometers/hour
"	0.003728	Miles/hour
Meters/second	196.8	Feet/minute
"	3.281	Feet/second
"	3.6	Kilometers/hour
"	0.06	Kilometers/minute
MegaPascal (MPa)	145.038	Lbs./sq. inch
Newton	0.225	Pound (Force)
"	0.102	Kg (Force)
Newton-Meter	0.737	Foot-Pound
"	8.85	Inch-Pound
Pounds/sq. foot	0.01602	Feet of water
"	4.883	Kgs./sq. meter
"	6.945×10^{-3}	Pounds/sq. inch
Pounds/sq. inch	0.06804	Atmosphere
"	2.307	Feet of water
"	2.036	Inches of mercury
"	3.1	Kgs./sq. meter
Temp. (°C) + 273	1	Abs. temp. (°K)
Temp. (°C) + 17.78	1.8	Temp. (°F)
Temp. (°F) + 460	1	Abs. temp. (R)
Temp. (°F) + -32	5/9	Temp. (°C)

SPX®

Your local contact:



M&J Valve, An SPX Brand

19191 Hempstead Hwy

Houston, TX 77065

Phone: (800) 231-3690 Fax: (281) 807-2829

E-mail: mjvalve@spx.com

For more information about our worldwide locations, approvals, certifications, and local representatives, please visit www.spxfc.com.

SPX Corporation reserves the right to incorporate our latest design and material changes without notice or obligation. Design features, materials of construction and dimensional data, as described in this bulletin, are provided for your information only and should not be relied upon unless confirmed in writing.