

M&J VALVE

AN SPX BRAND

Expanding Gate Valve

Technical Bulletin

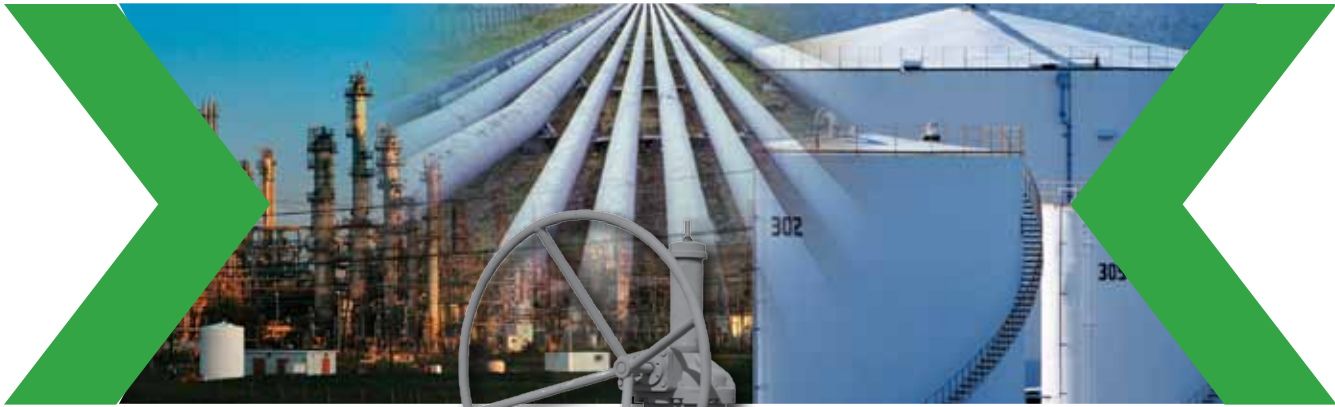

M&J VALVE

An SPX Process Equipment Operation

M&J Valve
19191 Hempstead Highway
Houston, TX 77065

Telephone: 281-469-0550
Fax: 281-894-1332

E-Mail: mandjvalve@processequipment.spx.com
Web Site: www.mandjvalve.com

SPX Process Equipment reserves the right to incorporate our latest design and material changes without notice or obligation. Design features, materials of construction and dimensional data, as described in this bulletin, are provided for your information only and should not be relied upon unless confirmed in writing. Certified drawings are available upon request.

Table of Contents

Design Types.....	3
Design Features	
Valve Operation	3
Emergency Seat Seal	4
Stem Features	4
Stem Sealing Features	4
Pressure Relief	4
Recommended Spare Parts.....	5
Service.....	5
Nameplate Data.....	5
Fire Test Qualifications.....	5
Standard Product/Options.....	5
Warranty.....	12
Trim Charts	
Exploded View	6
Figure Number Key.....	6
Trims for Selected Services	6
Trim Definitions	7
Seal Definitions	7
Drawings	
Assembly	2
Outline Dimensions.....	8,9
Yoke Tube Flange Dimensions	11
Engineering Data	
Operator Sizing	10
Weight Data	8,9

API 6D Expanding Gate Valves

The M&J Model EG valves are full bore through conduit valves with rising stem and parallel expanding gate and segment for tight mechanical seal and positive shut-off, both upstream and downstream, and under both low and high differential pressure. This design has proven performance in critical applications all over the world, such as isolation valves in power plants, ESD valves in production, block valves

in process systems, high temperature valves in refineries, and pipeline valves in critical areas. The M&J Model EG is constructed for increased reliability and ease of maintenance and operation. These valves are readily available in all the sizes, pressure ranges, and trims used in piping systems requiring the positive shut off of liquid or gas.

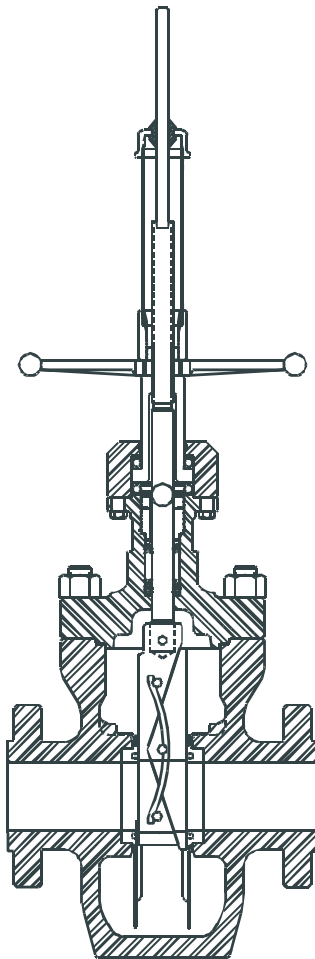

2" - 4"

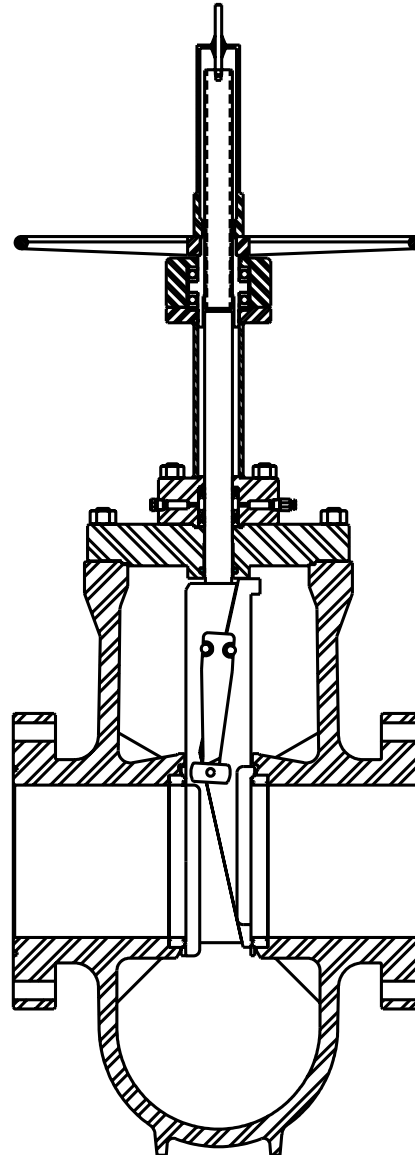

6" and Larger

API 6A NON-RISING STEM EXPANDING GATE VALVES

M&J also manufactures Model EG Non-Rising Stem Expanding Gate Valves. These valves are manufactured and tested in accordance with API 6A and are available in 2000 and 3000 psi working pressures.

Valve Operation

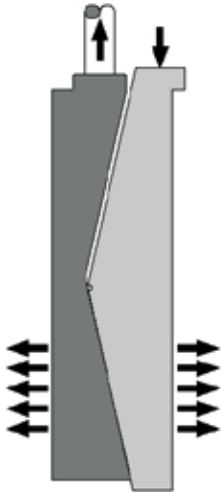

Open Position

The Expanding Gate Valve achieves its sealability by mechanically expanding the gate and segment assembly against the seats. The valve must be torqued fully open or fully closed to seal properly. Do NOT back off on the handwheel; leave it tight in both the open and closed positions. This method of operation prevents damage to the sealing surfaces of the gate and seat and isolates the body cavity preventing buildup of foreign material, increasing the life of the valve.

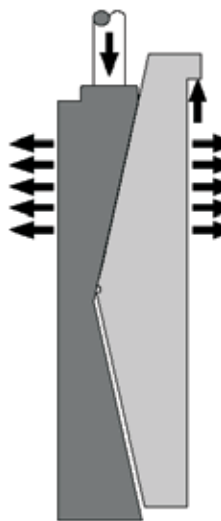

Closed Position

The valve's parallel expanding gate and segment provides a tight mechanical seat seal upstream and downstream and under low and high differential pressure conditions.

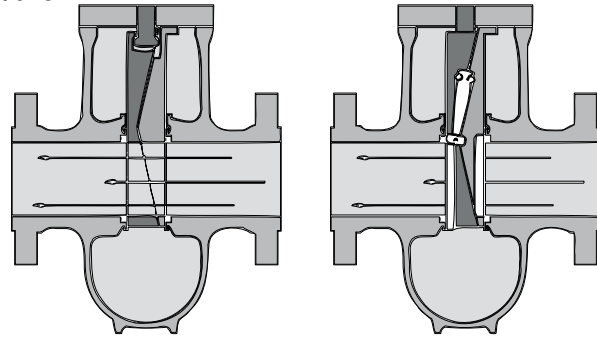

1. Travelling to the final open position the lower back angles are in contact with each other. With further upward movement of the gate with the segment stopped, the centralizer mechanism allows the gate-segment assembly to expand, sealing against both seats, protecting the seat faces from line flow, while isolating the body cavity from the flow bore.

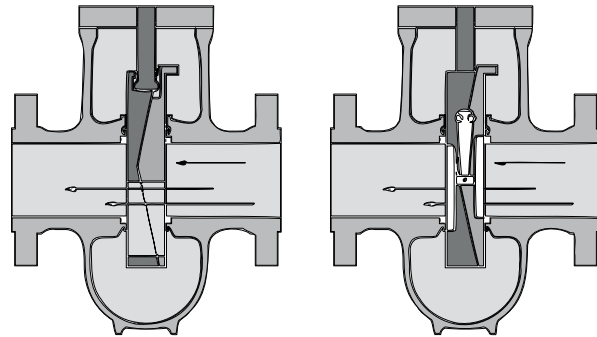

2. During open and closing travel, the gate-segment assembly is collapsed with both back angle surfaces in contact. The centralizer mechanism prevents relative movement between the gate and segment allowing the gate and segment assembly to travel freely without sticking or wedging.

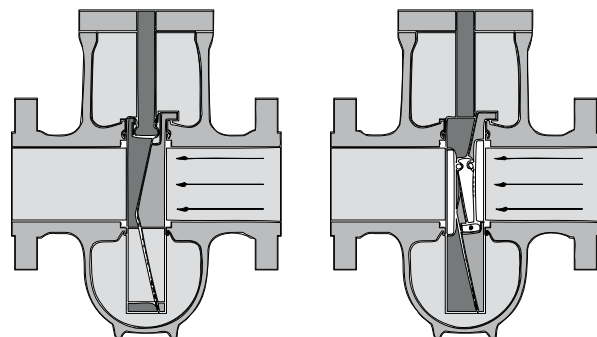

3. Travelling to the final closed position, the upper back angles of the gate and segment move into contact with each other. With further downward movement of the segment stopped, the centralizer mechanism allows the gate-segment assembly to expand, sealing against both seats, forming a tight mechanical seal.

Emergency Seat Seal

The M&J Expanding Gate Valve requires no lubrication. If foreign matter causes damage to the seat seal during operation, all valves are fitted with an emergency sealant injection provision (Fig. 1). Sealant can be injected directly to the seat sealing area to effect an emergency seal. If valves are to be buried, or in an inaccessible location, these fittings can be extended per the customer's requirements.

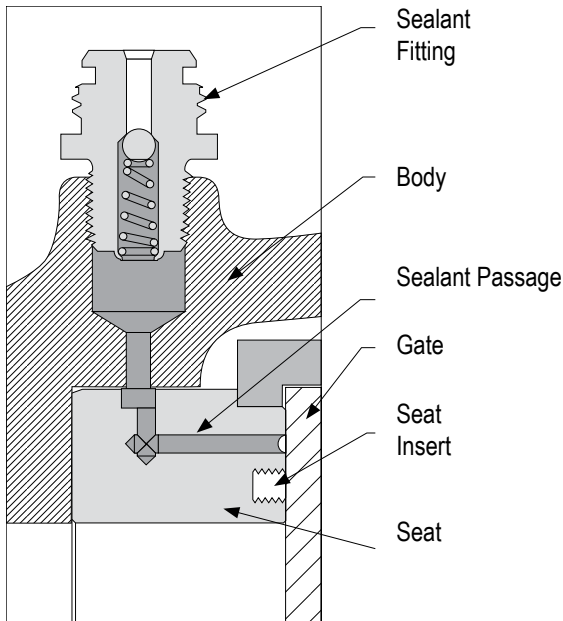

Fig. 1

Stem Features

The M&J Expanding Gate Valve is a one-piece stem design which has an integrally forged stem head.

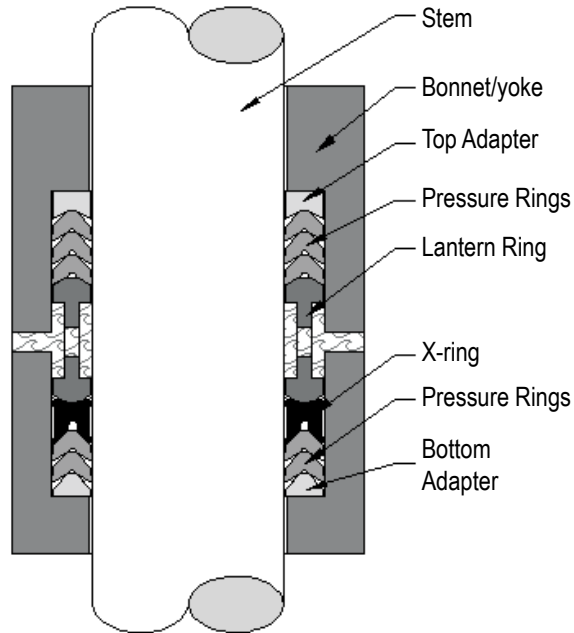

Fig. 2

Stem Sealing Features

The stem seal design (Fig. 2) utilizes Chevron rings to insure sealing integrity. The packing box seal configuration is an open/closed design to allow emergency bulk packing injection in the event of a stem leak. Alternate seal designs are available to meet a wide variety of customers requirements.

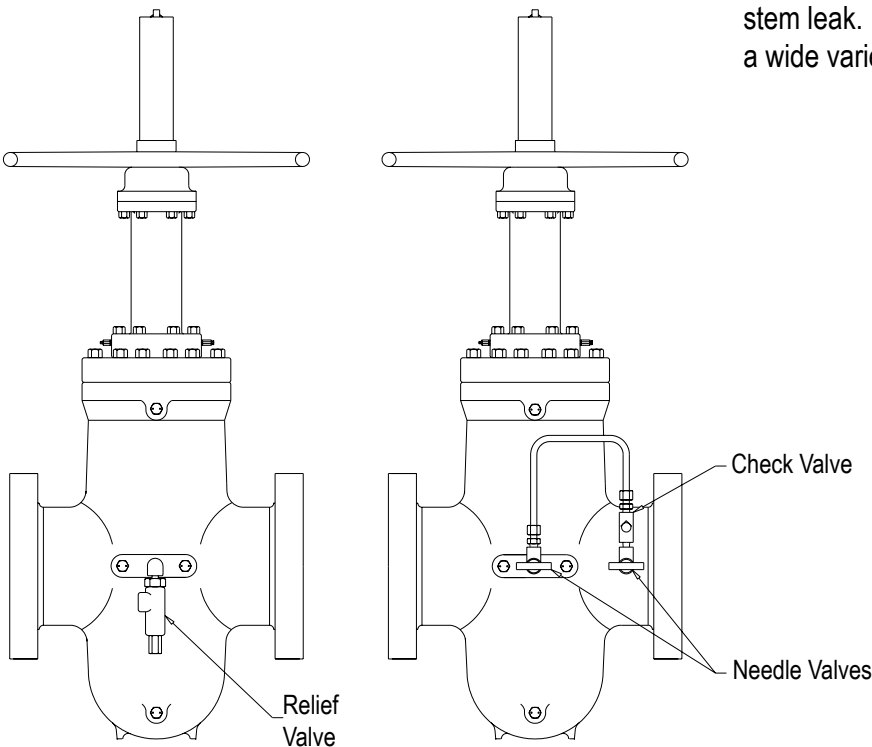

Fig. 3a

Fig. 3b

Pressure Relief

The M&J Expanding Gate Valve design will trap pressure in the valve body cavity when the valve is in the full open or closed position. High internal pressures can result from thermal expansion. To protect the valve from overpressure, the valve is provided with upstream relief piping which relieves excess body pressure to the upstream side of the valve (Fig. 3B). As an alternate, a relief valve can be provided (Fig. 3A).

Recommended Spare Parts

It is recommended that the following spare parts be inventoried in operations having numerous valves of a given size and an in-house maintenance program:

Part Description	Number of valves to be supported			
	<10	11-20	21-30	31-40
Gate & Segment Assembly	0	1	2	3
Seat Assembly	0	2	4	6
Stem	0	1	2	3
Bonnet & Yoke Seals	1	2	3	4
Packing Set	1	2	4	6
Gear Box	0	0	1	1
Handwheel	0	1	2	2
Vent/Grease Fitting	2	4	8	12
Injectible Packing (Box)	1	2	4	4
Body Relief Valve	1	2	4	6
Packing Injection Fitting	1	2	4	6
Stem Nut Bearings, Set	1	2	2	4

Nameplate Data

Nameplates on M&J Expanding Gate Valves provide all of the necessary information to identify the valve when contacting the factory for spares or assistance.

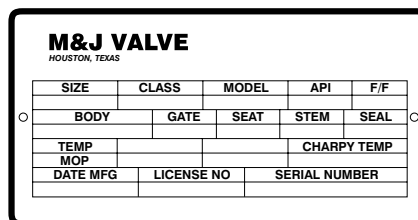

Service

M&J Valve Company does not just sell you a product and forget about you. Every product sold by M&J Valve Company is supported by our full staff. This staff is available to provide you with technical advice, backup documentation, spare parts and repair services, either in the plant or the field. Our well trained and experienced field service staff stands ready to support you and our products around the world.

Fire Test Qualifications

M&J Expanding Gate Valves have been designed to meet the most stringent standards. Part of this is fire testing to the requirements of API-6FA. In addition to the normal in-house testing program, fire tests have been witnessed and certified by independent authorities. Fire test qualified design and certification can be provided, when specified.

Standard Product And Available Options

Feature	Standard	When Specified
API-6D/Q1	X	
ISO 9001	X	
Handwheel Operator	2" - 12"	
Bevel Gear Operator	14" & LGR	4" - 12"
Power Actuator		X
Double Block & Bleed		X
Hidden Secondary Sealant Check		X
Buried Service	Extended Stem	X
	Extended Sealant, Vent & Drain	X
Locking Device		X
Transition Piece (Pups)		X
Emergency Packing Injection	X	
External Relief	X	
External Piping to Upstream		X
Body Vent Fitting	X	
Body Drain/Injection Fitting	X	
Lift	6" - 12"	X
Lugs	14" & up	X
Body Footing	X	
Stem Position Indicator	X	

Feature	Standard	When Specified	
Outside Packing Gland	X		
API Monogram	X		
API-6D Test:	Hydro-Shell	X	
	Hydro-Seat	X	
	Air Seat		X
	Operational Torque Test		X
NDE:	Extended Hydro Test		X
	Visual (API 6D)	X	
	Ultrasonic		X
	Dye Penetrant		X
	Magnetic Particle		X
Documentation/ Certification:	Radiography		X
	Hydrotest Reports		X
	Material Test Reports (MTRs)		X
	Hydrotest Charts		X
	NDE Reports		X
	NACE		X
	Fire-Test Certification		X
Certificate of Compliance		X	
Operational Test Reports		X	

Figure Number Key

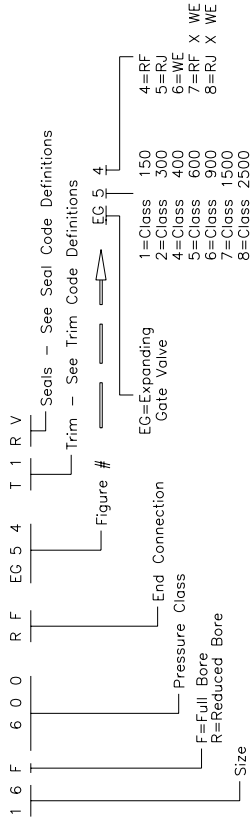

Standard Metallic Trims For Selected Services

T1 - Standard - Carbon Steel -- Hydrocarbons
T3 - Full Stainless Steel - Highly Corrosive
T4 - Carbon Steel - NACE
T6 - Carbon Steel - 410SS Internals - NACE
T7 - Brine - Salt - Mildly Corrosive - NACE
T8 - Waterflood - Brine - NACE
S4 - Carbon Steel - NACE - 17-PH Stem
G1 - High Temperature - Geothermal
G2 - High Temperature - Geothermal - HF Gate
L1 - Low Temperature - Carbon Steel
L4 - Low Temperature - NACE Carbon Steel

ENP - Electroless Nickel Plated
HF - Hard Faced

Note: This is a sample of services and standard trims.
For assistance with a specific service, contact your local M&J representative.

Exploded View

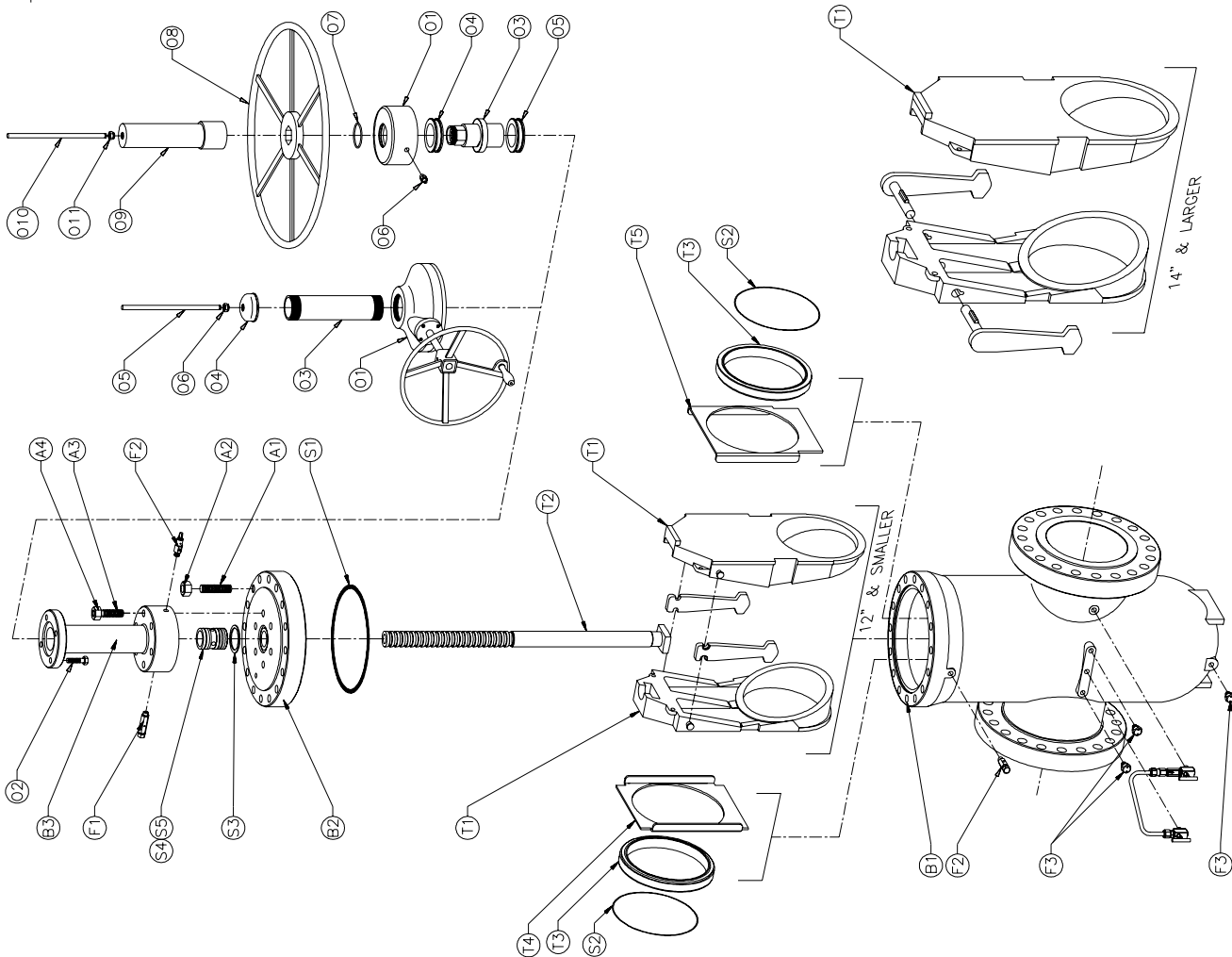

Trim Code Definitions

Item	Description	T1	L1	T3	T4	L4	T6	T7	T8	S4	G1	G2
B1	Body	ASTM A216 WCC	ASTM A350 LCC	ASTM A351 CF8M	ASTM A216 WCC	ASTM A350 LCC	ASTM A216 WCC	ASTM A216 WCC/ EPOXY COATED	ASTM A216 WCC/ EPOXY COATED	ASTM A216 WCC	ASTM A216 WCC	ASTM A216 WCC
B2	Bonnet	ASTM A516 GR. 70	ASTM A537 CL1	ASTM A516SS	ASTM A516 GR. 70	ASTM A537 CL1/A333	ASTM A516 GR. 70	ASTM A516 GR. 70/ EPOXY COATED	ASTM A516 GR. 70/ EPOXY COATED	ASTM A516 GR. 70	ASTM A516 GR. 70	ASTM A516 GR. 70
B3	Yoke Tube	ASTM A516/A36/A53	ASTM A537 CL1/A333	ASTM A516/A36/A53 625 CLAD PKG BOX	ASTM A516/A36/A53	ASTM A537 CL1/A333	ASTM A516/A36/A53	ASTM A516/A36/A53	ASTM A516/A36/A53	ASTM A516/A36/A53	ASTM A516/A36/A53	ASTM A516/A36/A53
T1	Gate & Segment	ASTM A216 GR. WCC/ENP	ASTM A216 GR. WCC/ENP	ASTM A351 CF8M	ASTM A216 GR. WCC/ENP	ASTM A216 GR. WCC/ENP	ASTM A487 GR CA6NM	ASTM A216 GR WCC/ENP	ASTM A747 GR CB7CL-1 (17-4PH)	ASTM A216 GR WCC/ENP	ASTM A216 GR WCC/ENP	ASTM A216 GR WCC/ENP
T2	Stem	ASTM A516 GR. 70	ASTM A537 CL1	ASTM A516SS	ASTM A516 GR. 70	ASTM A537 CL1/A333	ASTM A516 GR. 70	ASTM A516 GR. 70/ EPOXY COATED	ASTM A516 GR. 70/ EPOXY COATED	ASTM A516 GR. 70	ASTM A516 GR. 70	ASTM A516 GR. 70
T3	Seat Assembly	ASTM A516/A36/A53	ASTM A537 CL1/A333	ASTM A516/A36/A53 625 CLAD PKG BOX	ASTM A516/A36/A53	ASTM A537 CL1/A333	ASTM A516/A36/A53	ASTM A516/A36/A53	ASTM A516/A36/A53	ASTM A516/A36/A53	ASTM A516/A36/A53	ASTM A516/A36/A53
T4	Gate Skirt	ASTM A36	ASTM A36	ASTM A316SS	ASTM A36	ASTM A36	ASTM A36	ASTM A36/ENP	ASTM A36/ENP	ASTM A36	ASTM A36	ASTM A36
T5	Segment Skirt	ASTM A36	ASTM A36	ASTM A316SS	ASTM A36	ASTM A36	ASTM A36	ASTM A36/ENP	ASTM A36/ENP	ASTM A36	ASTM A36	ASTM A36
A1	Body/Bonnet Studs	ASTM A193 B7	ASTM A320 L7	ASTM A193 B7 FLR/CTD	ASTM A193 B7M	ASTM A320 L7M	ASTM A193 B7	ASTM A193 B7M	ASTM A193 B7M	ASTM A193 B7M	ASTM A193 B7M	ASTM A193 B7M
A2	Body/Bonnet Nuts	ASTM A194 2H	ASTM A194 GR. 7	ASTM A194 2H FLR/CTD	ASTM A194 2HM	ASTM A194 GR. 7M	ASTM A194 2H	ASTM A194 2HM	ASTM A194 2HM	ASTM A194 2HM	ASTM A194 2HM	ASTM A194 2HM
A3	Yoke Tube/Bonnet Studs	ASTM A193 B7	ASTM A320 L7	ASTM A193 B7 FLR/CTD	ASTM A193 B7M	ASTM A320 L7M	ASTM A193 B7	ASTM A193 B7M	ASTM A193 B7M	ASTM A193 B7M	ASTM A193 B7M	ASTM A193 B7M
A4	Yoke Tube/Bonnet Nuts	ASTM A194 2H	ASTM A194 GR. 7	ASTM A194 2H FLR/CTD	ASTM A194 2HM	ASTM A194 GR. 7M	ASTM A194 2H	ASTM A194 2HM	ASTM A194 2HM	ASTM A194 2HM	ASTM A194 2HM	ASTM A194 2HM
F1	Packing Filling	Steel	18-8 SST	18-8 SST	18-8 SST	18-8 SST	18-8 SST	18-8 SST	18-8 SST	18-8 SST	18-8 SST	18-8 SST
F2	Packing Plug/Vent	Steel	18-8 SST	18-8 SST	18-8 SST	18-8 SST	18-8 SST	18-8 SST	18-8 SST	18-8 SST	18-8 SST	18-8 SST
F3	Body/Vent/Grs Filling	Steel	18-8 SST	18-8 SST	18-8 SST	18-8 SST	18-8 SST	18-8 SST	18-8 SST	18-8 SST	18-8 SST	18-8 SST

Seal Code Definitions

Item	Description	RV	GT	LR	GV
S1	Body/Bonnet Seal	18-8SST/Grafoil	18-8SST/Grafoil	18-8SST/Grafoil	18-8SST/Grafoil
S2	Sediment Seal	Viton	EPDM	Viton	Viton
S3	Yoke Tube Gasket	18-8SST/Grafoil	18-8SST/Grafoil	18-8SST/Grafoil	18-8SST/Grafoil
S4	Packing Set	Ryton Filled TFE	40% Glass Filled TFE	Ryton/Viton	Graphoil
S5	Lantern Ring	Not Req'd.	Not Req'd.	AISI 1018/ ENP	AISI 1018/ENP
	Temperature Range	0 - 350	0 - 550	0 - 350	0 - 550

Seal Definitions

- RV - Ryton/Viton
- LR - Lantern Ring/Ryton/Viton
- GT - Geothermal/EPR
- GV - Graphoil/Viton

2" - 30" Rising Stem Expanding Gate Valves

Principal Dimensions

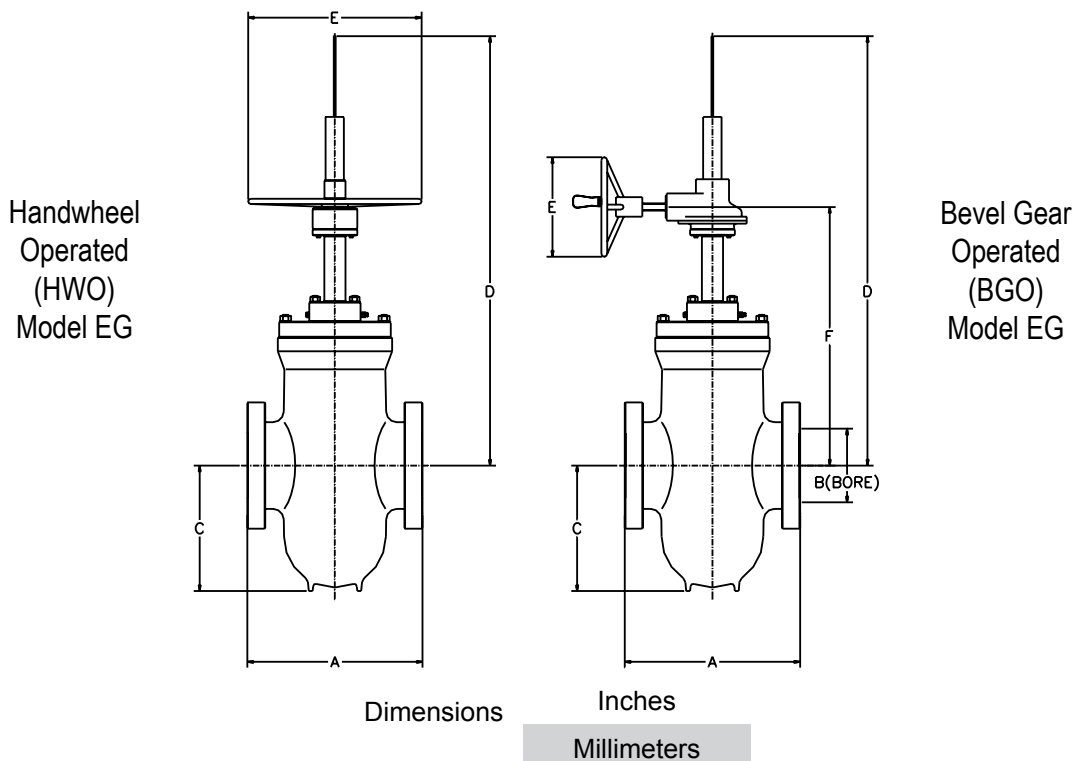

SIZE	CLASS 300									
	A (RJ)	A (RF)	B	C	D (HWO)	D (BGO)	E (HWO)	E (BGO)	F (BGO)	WEIGHT (LBS) (KGS)
6	16.50	15.88	6	12.63	50.25	51.25	18	18	29.50	550
150	419	403	152	321	1,276	1,302	457	457	749	249
8	17.13	16.50	8	15.50	61	62	26	24	35.63	850
200	435	419	203	394	1,550	1,575	660	610	905	385
10	18.63	18	10	20	73.25	74.25	32	24	43.38	1,250
250	473	457	254	508	1,860	1,886	813	610	1,102	567
12	30.13*	30*	12	23	82.13	85.88	32	28	49.25	1,900
300	765	762	305	584	2,086	2,181	813	711	1,251	862
12-3/8	30.13*	30*	12.38	23	82.13	85.13	32	28	49.25	1,900
300	765	762	314	584	2,086	2,162	813	711	1,251	862
12-1/2	30.13*	30*	12.50	23	82.13	85.13	32	28	49.25	1,900
300	765	762	318	584	2,086	2,162	813	711	1,251	862
16	33.63	33	15.25	28.75	-	101.25	-	30	58.50	3,500
400	854	838	387	730	-	2,572	-	762	1,486	1,587
20	41.75*	41.5*	19.25	38.5	-	123.75	-	36	75	6,500
500	1,060	1,054	489	978	-	3,143	-	914	1,905	2,948
24	45.88	45	23.25	51.5	-	144	-	36	88	11,500
600	1,165	1,143	591	1,308	-	3,658	-	914	2,235	5,215
30	-	60	29	60	-	172	-	36	102	18,500
300	-	1,524	737	1,524	-	4,369	-	914	2,591	8,391

*400 End-To-End

Flange dimensions conform to American National Standard Institute Standard B16.5.

Other sizes and pressures available on request.

Information on power-actuated and other types available on application.

2" - 30" Rising Stem Expanding Gate Valves

SIZE	CLASS 600									
	A	A	B	C	D	D	E	E	F	WEIGHT
DN	(RJ)	(RF)			(HWO)	(BGO)	(HWO)	(BGO)	(BGO)	(LBS.) (KGS.)
2	11.63	11.5	2.06	5.38	17.75	-	12	-	-	95
50	295	292	52	137	451	-	305	-	-	43
3	14.13	14	3.13	7.38	27	-	12	-	-	190
75	359	356	80	187	686	-	305	-	-	86
4	17.13	17	4.06	8.88	31.25	-	16	-	-	350
100	435	432	103	226	794	-	406	-	-	159
6	22.13	22	6	12.63	43	44	18	18	29.5	695
150	562	559	152	226	1,092	1,118	457	457	749	315
8	26.13	26	8	15.5	55	56	26	24	35.63	1,025
200	664	660	203	394	1,397	1,422	660	610	905	465
10	31.13	31	10	19.75	65	66	32	24	43.38	1,750
250	791	787	254	502	1,651	1,676	813	610	1,102	794
12	33.13	33	12	23	66.25	70	32	28	49.25	2,600
300	942	838	305	584	1,683	1,778	813	711	1,251	1,179
12-3/8	33.13	33	12.38	23	66.25	70	32	28	49.25	2,600
300	842	838	314	584	1,683	1,778	813	711	1,251	1,179
12-1/2	33.13	33	12.5	23	66.25	70	32	28	49.25	2,600
300	842	838	318	584	1,683	1,778	813	711	1,251	1,179
16	39.13	39	15.25	28.75	-	81	-	30	61.25	4,450
400	994	991	387	730	-	2,057	-	762	1,556	2,018
20	47.25	47	19.25	38.5	-	107	-	36	75	7,400
500	1,200	1,194	489	978	-	2,718	-	914	1,905	3,356
24	55.38	55	23.25	51.5	-	144	-	36	88	12,000
600	1407	1397	591	1,308	-	3,658	-	914	2,235	5,442
30	-	65	29	60	-	172	-	36	102	24,200
600	-	1,651	737	1,524	-	4,369	-	914	2,591	10,977

SIZE	CLASS 900									
	A	A	B	C	D	D	E	E	F	WEIGHT
DN	(RJ)	(RF)			(HWO)	(BGO)	(HWO)	(BGO)	(BGO)	(LBS.) (KGS.)
2	14.63	14.5	2.06	5.38	17.75	-	12	-	-	145
50	372	368	52	137	451	-	305	-	-	66
3	15.13	15	3.13	7.38	27	-	12	-	-	260
75	384	381	80	187	686	-	305	-	-	118
4	18.13	18	4.06	9	31.25	-	16	-	-	510
100	461	457	103	229	794	-	406	-	-	231
6	24.13	24	6	12.81	45	46	18	18	29.5	860
150	613	610	152	325	1,143	1,168	457	457	749	390
8	29.13	29	8	15.75	55	56	26	24	35.63	1,270
200	740	737	203	400	1,397	1,422	660	610	905	576
10	33.13	33	10	20	65	66	32	24	43.63	2300
250	842	838	254	508	1,651	1,676	813	610	1,108	1,043
12	38.13	38	12	23.5	66.25	66	32	30	49.25	3,500
300	969	965	305	597	1,683	1,676	813	762	1,251	1,587
12-3/8	38.13	38	12.38	23.5	66.25	70	32	30	49.25	3,500
300	969	965	314	597	1,683	1,778	813	762	1,251	1,587
12-1/2	38.13	38	12.5	23.5	66.25	70	32	30	49.25	3,500
300	969	965	318	597	1,683	1,778	813	762	1,251	1,587
16	44.88	44.5	14.75	30.25	-	81	-	30	66.5	7,300
400	1,140	1,130	375	768	-	2,057	-	762	1,689	3,311
20	52.5	52	18.63	51.5	-	107	-	36	75	9,200
500	1,334	1,321	473	1,118	-	2,718	-	914	1,905	4,172

Operator Sizing Requirements

3" - 4" Classes 600 - 900

6" - 30" Classes 300 - 900

SIZE	CLASS	ANSI WORKING PRESSURE		STEM THREAD		RECOMMENDED OPERATING THRUST		RECOMMENDED OPERATING TORQUE		MAXIMUM ALLOWABLE THRUST		MAXIMUM ALLOWABLE TORQUE		TOTAL STEM TRAVEL		TURNS TO OPEN	
		psi	Kg/cm ²	SIZE	PITCH	LEAD	Lb	Kgs	Ft-Lb	N-M	Lb	Kgs	Ft-Lb	N-M	in		mm
3	600	1,500	105	1,000	0.200	0.200	4,064	1,843	31	42	19,944	9,045	153	207	4.03	102.3	20
	900	2,250	158				6,097	2,765	47	63							
4	600	1,500	105	1,250	0.250	0.250	6,612	2,999	63	86	31,868	14,453	305	413	4.88	124	19.5
	900	2,250	158				9,918	4,498	95	129							
6	300	750	53				6,400	2,902	73	99	48,000	21,769	546	740	7.06	179.3	25
	600	1,500	105	1,500	0.286	0.286	12,800	5,805	146	197							
8	300	750	53				10,994	4,986	161	219							28
	600	1,500	105	2,000	0.333	0.333	21,987	9,972	322	437	94,177	42,711	1,380	1,872	9.25	235	
10	300	750	53				16,126	7,313	259	351	127,226	57,699	2,041	2,767	11.38	289	34
	600	1,500	105	2,250	0.333	0.333	32,251	14,626	517	702							
12	300	750	53				48,377	21,940	776	1,052							40
	600	1,500	105	2,250	0.333	0.333	21,574	9,784	346	469	127,226	57,699	2,041	2,767	13.31	338	
16	300	750	53				64,723	29,353	1,038	1,408							50
	600	1,500	105	2,500	0.333	0.333	32,444	14,714	566	767	168,876	76,588	2,944	3,992	16.63	422.4	
20	300	750	53				64,887	29,427	1,131	1,534							55
	600	1,500	105	2,875	0.400	0.400	97,331	44,141	1,697	2,301	220,220	99,873	4,460	6,047	22.00	559	
24	300	750	53				50,698	22,992	1,027	1,392							42
	600	1,500	105	2,63	0.333	0.666	101,396	45,984	2,053	2,784	175,865	79,771	3,994	5,415	28.13	715	
30	300	750	53				151,845	68,876	3,449	4,676							41
	600	1,500	105	3.13	0.400	0.800	112,888	51,205	3,063	4,153	250,000	113,400	6,800	9,220	32.88	835	

- Notes:
- Recommended operating thrust and torque values are the loads required to open and close the valve. These torques do not contain service or safety factors.
 - Recommended operating torque and thrust values are based on maximum working pressure at ambient temperature. To obtain expected torques at lower temperatures, contact your m&j representative.
 - Actuator selection should be made based on experience and appropriate service/safety factors.
 - Maximum allowable thrust and torque values are the maximum allowable loads of the valve.
 - For sizes/classes not listed, contact your m&j representative.

Yoke Tube Flange Dimensions

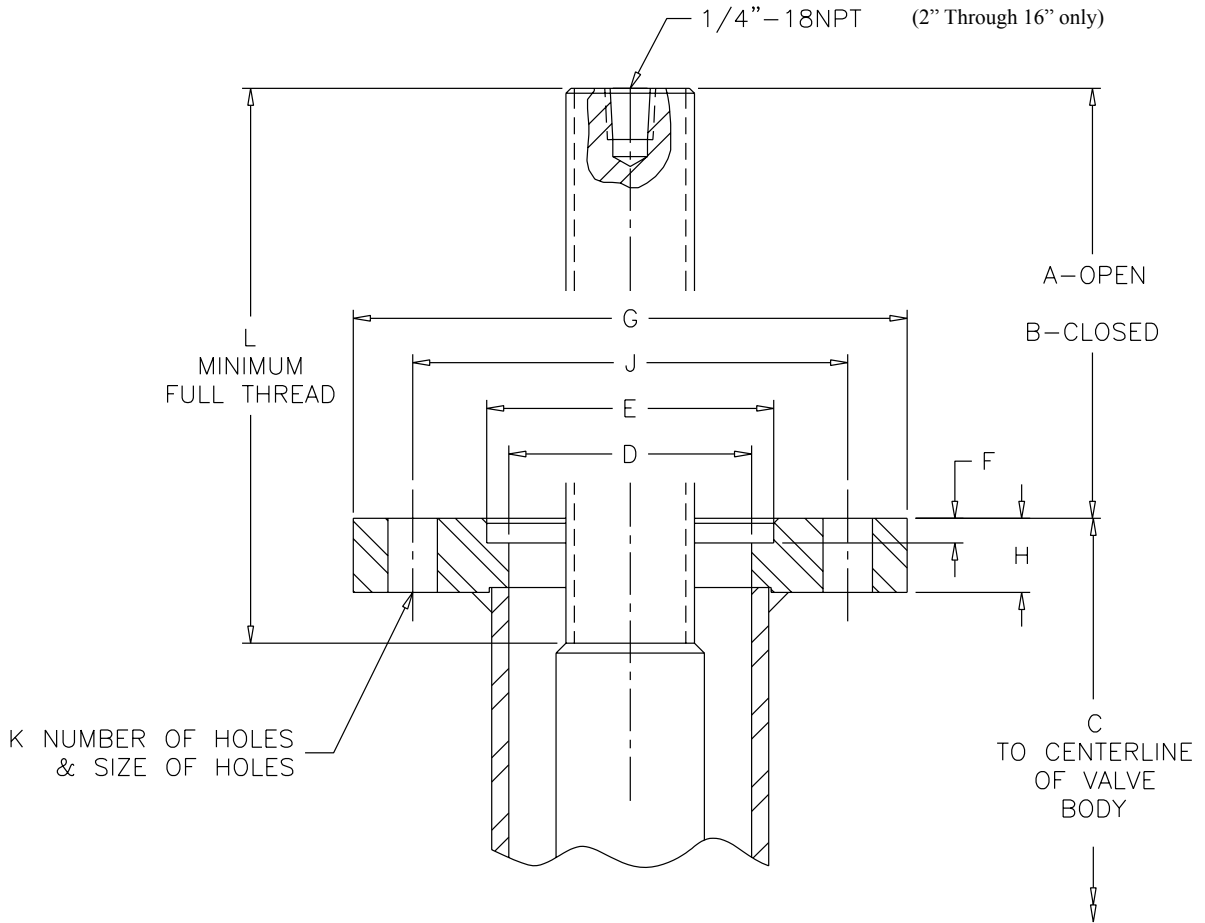

SIZE	CLASS	A	B	C	D	E	F	G	H	J	K	L
6	300-900	11.31	4.25	26.31	2.56	3.765	.19	8.50	1.25	*5.50	(4) .69 DIA. STRADDLE CL	11
						3.775				*6.50	(4) .81 DIA. ON CL	
8	300-900	15.13	5.88	32.13	3.38	3.765	.19	8.50	1.25	*5.50	(4) .69 DIA. STRADDLE CL	15
						3.775				*6.50	(4) .81 DIA. ON CL	
10	300-900	17.56	6.19	39.75	3.38	3.765	.19	8.50	1.25	*5.50	(4) .69 DIA. STRADDLE CL	17.50
						3.775				*6.50	(4) .81 DIA. ON CL	
12	300-900	19.50	6.19	44.75	3.38	5.015 5.025	.25	8.50	1.25	6.50	(4) .81 DIA. STRADDLE CL	19.50
16	300-900	22.75	6.13	56.75	3.50	5.015 5.025	.25	8.31	1.50	6.50	(4) .81 DIA. STRADDLE CL	24
20	300-900	30.63	8.63	65.50	6.06	7.005 7.010	.31	13.50	2.63	11.75	(8) .88 DIA. STRADDLE CL	31.25
24	300-600	38.06	9.94	81.00	5.04	7.005 7.010	.31	13.50	1.63	11.75	(8) .88 DIA. STRADDLE CL	37.5
30	300-600	43.38	10.50	93.13	6.06	8.505	.31	16.75	2.63	14.0	(8) 1.38 DIA STRADDLE CL	43.5
						8.510						

* These sizes have both hole patterns in the mounting flange.

Notes



Your local contact:



M&J Valve, An SPX Brand
19191 Hempstead Hwy
Houston, TX 77065
Phone: (800) 231-3690 Fax: (281) 807-2829
E-mail: mjvalve@spx.com
www.mandjvalve@spx.com
www.spxft.com



For more information about our worldwide locations, approvals, certifications, and local representatives, please visit www.spxfc.com.

SPX Corporation reserves the right to incorporate our latest design and material changes without notice or obligation.

Design features, materials of construction and dimensional data, as described in this bulletin, are provided for your information only and should not be relied upon unless confirmed in writing.