

Expanding Gate Valve

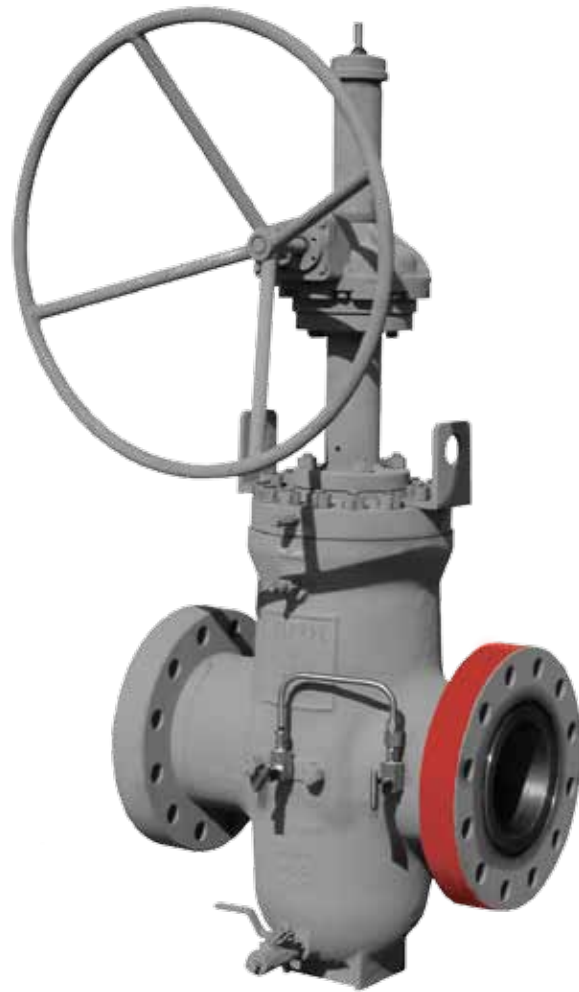

M&J Valve was founded in 1962 by Marvin Grove and has been a leader in the pipeline valve industry since its inception. Now part of SPX Flow Technology, M&J Valve meets or exceeds the quality standards of our customers and the valve industry. M&J Valve product offering includes slab and expanding through-conduit gate valves, axial surge valves and rotary control valves, piston, ball, and swing check valves. M&J Valve can provide a wide variety of flow control solutions for liquid and gas markets. This combination of products, technical know-how and field experience has allowed for a history of product innovation which has positioned M&J Valve in a leadership position within the valve industry.

Finding innovative ways to help the world meet its ever growing demand for energy is a key focus for SPX. As a multi industry manufacturer, we provide creative solutions that serve global energy markets in a myriad of ways. SPX is helping to meet that demand with a broad range of high quality, custom-engineered systems and components that can also help improve efficiency and reduce the use of natural resources. We also supply a wide range of components — from air preheaters to filter systems. SPX off-the-shelf and customized solutions are supporting all phases of oil, gas and biofuel production, from exploration, extraction and processing to transport and storage.

For A Dependable Shutoff Count On The Sealing Reliability of the M&J Model EG Expanding Gate Valve

The M&J Model EG valves are full bore through conduit valves with rising stem and parallel expanding gate and segment for tight mechanical seal and positive shut-off, both upstream and downstream, and under both low and high differential pressure. The Model EG valve provides a superior bi-directional mechanical seal because the two-piece gate assembly expands against the seating areas in the open or closed position. The greater the torque, the tighter the seal. The end result is an extremely heat resistant seal that is unaffected by line pressure or vibration.

This design has proven performance in critical applications all over the world, such as isolation valves in power plants, ESD valves in production, block valves in process systems, high temperature valves in refineries, and pipeline valves in critical areas. The M&J Model EG is constructed for increased reliability and ease of maintenance and operation. These valves are readily available in all the sizes, pressure ranges, and trims used in piping systems requiring the positive shut off of liquid or gas.

GENERAL SPECIFICATIONS

- Sizes: 2" and larger in all ANSI classes
- Temperature range: -50° F to +1000° F
- Flanged end connections/ Weld End Connections
- Fire tested to API-6FA
- ISO 9001
- Available: NACE, high corrosive, high and low temperature
- Geothermal trims

FEATURES

- Increased throughput full bore unrestricted flow
- Tight seal in all flow conditions; bi-directional mechanical sealing
- Can replace two valves; double block and bleed capability
- Long, leak free service life; protected seat design
- Easy to operate; low operating torque; single piece stem; visual indication of position
- Easy to maintain; stem packing does not require lubrication; backup sealing options; emergency sealing through the stem and seat; can be overhauled in-line; top entry access to all internals

OPTIONS

- Wide range of trims
- Can be manual, electric, or hydraulic actuators
- Stem and sealant injection extensions for buried service
- Locking devices
- Wide range of testing and verification procedures
- Zero emission secondary stem seals

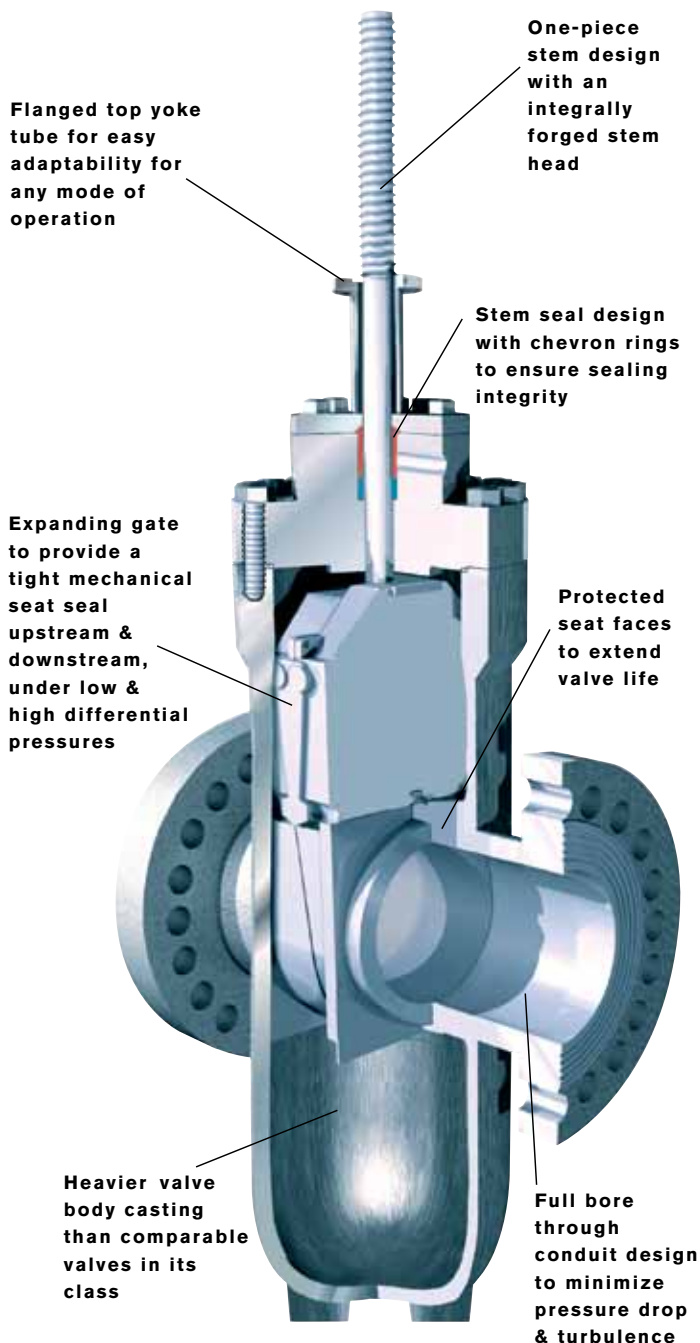

Typical product applications

The M&J Model EG valves are used in a wide range of critical applications, from pipelines to power plants, in ESD and other demanding isolation applications.

Oil, Gas, Liquid Products & Secondary Recovery

Mainline Block Valves

Tank and Station Valves

Block & Bleed Valves

Manifold Valves

Launcher/Receiver Trap Valves

Meter Bypass Valves

Emergency Shutdown Valves

Hot Tap Valves



M&J EG EXPANDING GATE VALVES ARE AVAILABLE IN 2" AND LARGER IN ALL ANSI CLASSES.

PRINCIPLE OF OPERATION

Valve Operation

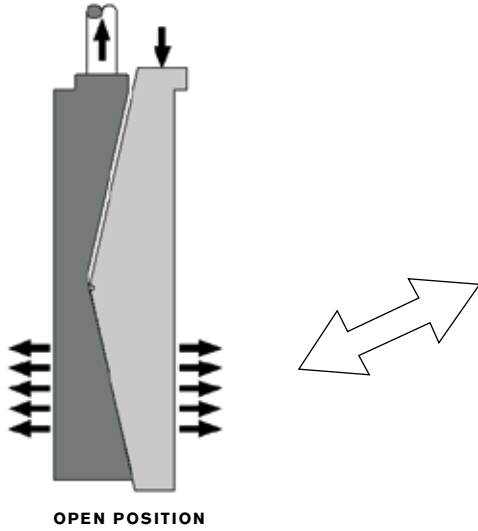

The Expanding Gate Valve achieves its sealability by mechanically expanding the gate and segment assembly against the seats. The valve must be torqued fully open or fully closed to seal properly. Do NOT back off on the handwheel; leave it tight in both the open and closed positions. This method of operation prevents damage to the sealing surfaces of the gate and seat and isolates the body cavity preventing buildup of foreign material, increasing the life of the valve.

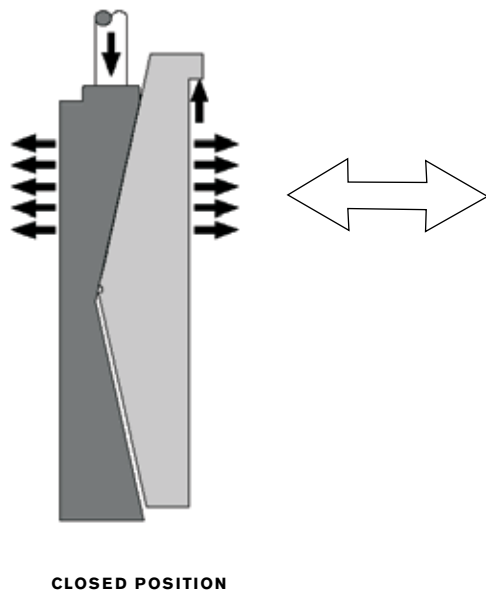

The valve's parallel expanding gate and segment provides a tight mechanical seat seal upstream and downstream and under low and high differential pressure conditions.

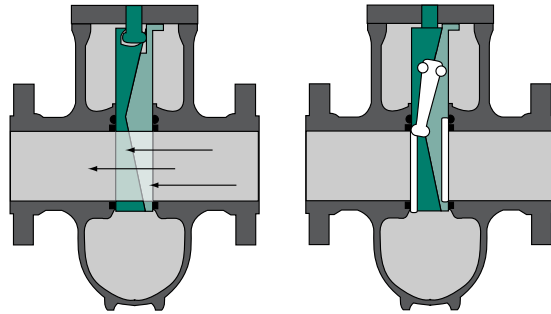

1.) Traveling to the final open position the lower back angles are in contact with each other. With further upward movement of the gate with the segment stopped, the centralizer mechanism allows the gate-segment assembly to expand, sealing against both seats, protecting the seat faces from line flow, while isolating the body cavity from the flow bore.

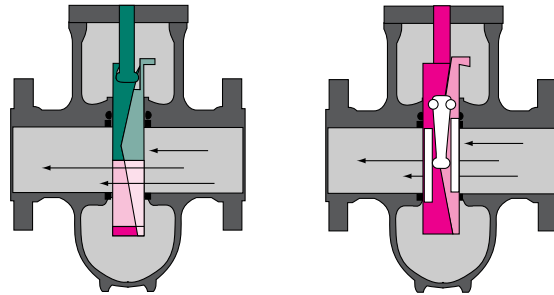

2.) During open and closing travel, the gate-segment assembly is collapsed with both back angle surfaces in contact. The centralizer prevents relative movement between the gate and segment allowing the gate and segment assembly to travel freely without sticking or wedging.

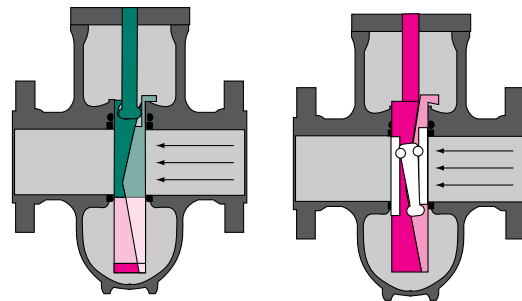

3.) Traveling to the final closed position, the upper back angles of the gate and segment move into contact with each other. With further downward movement of the segment stopped, the centralizer mechanism allows the gate-segment assembly to expand, sealing against both seats, forming a tight mechanical seal.

EMERGENCY SEAT SEAL

The M&J Expanding Gate Valve requires no lubrication. If foreign matter causes damage to the seat seal during operation, all valves are fitted with an emergency sealant injection provision (Fig. 1). Sealant can be injected directly to the seat sealing area to effect an emergency seal. If valves are to be buried, or in an inaccessible location, these fittings can be extended per the customer's requirements.

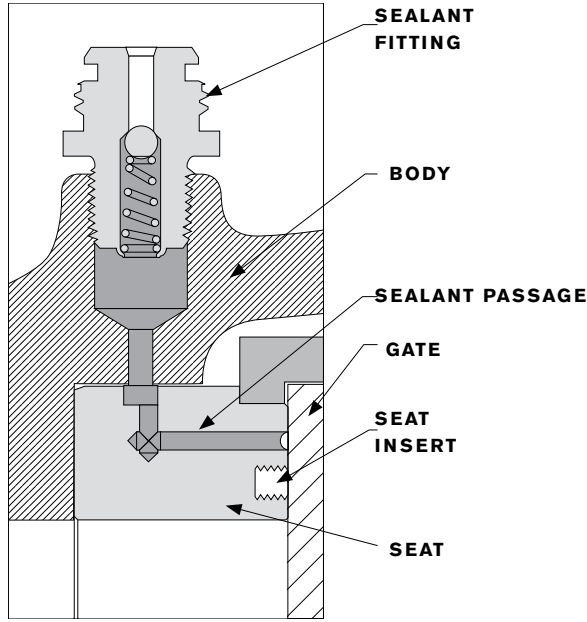

FIG. 1

STEM FEATURES

The M&J Expanding Gate Valve is a one-piece stem design which has an integrally forged stem head.

STEM SEALING FEATURES

The stem seal design (Fig. 2) utilizes Chevron rings to insure sealing integrity. The packing box seal configuration is an open/closed design to allow emergency bulk packing injection in the event of a stem leak. Alternate seal designs are available to meet a wide variety of customers requirements.

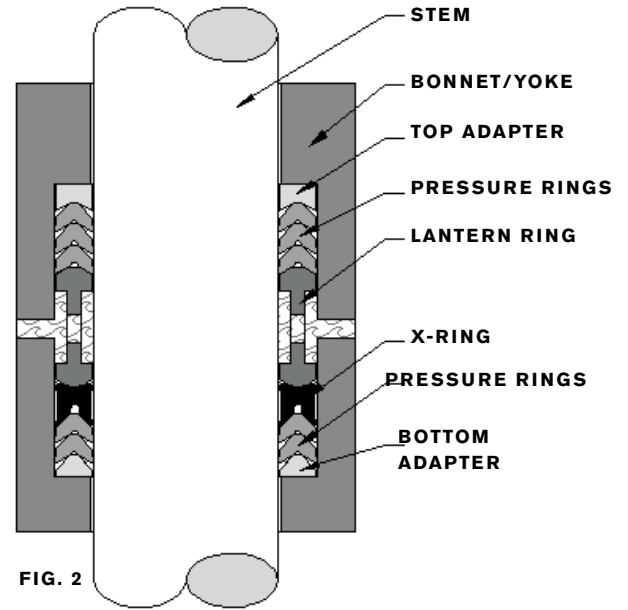

FIG. 2

PRESSURE RELIEF

The M&J Expanding Gate Valve design will trap pressure in the valve body cavity when the valve is in the full open or closed position. High internal pressures can result from thermal expansion. To protect the valve from overpressure, the valve is provided with upstream relief piping which relieves excess body pressure to the upstream side of the valve (Fig. 3B). As an alternate, a relief valve can be provided (Fig. 3A).

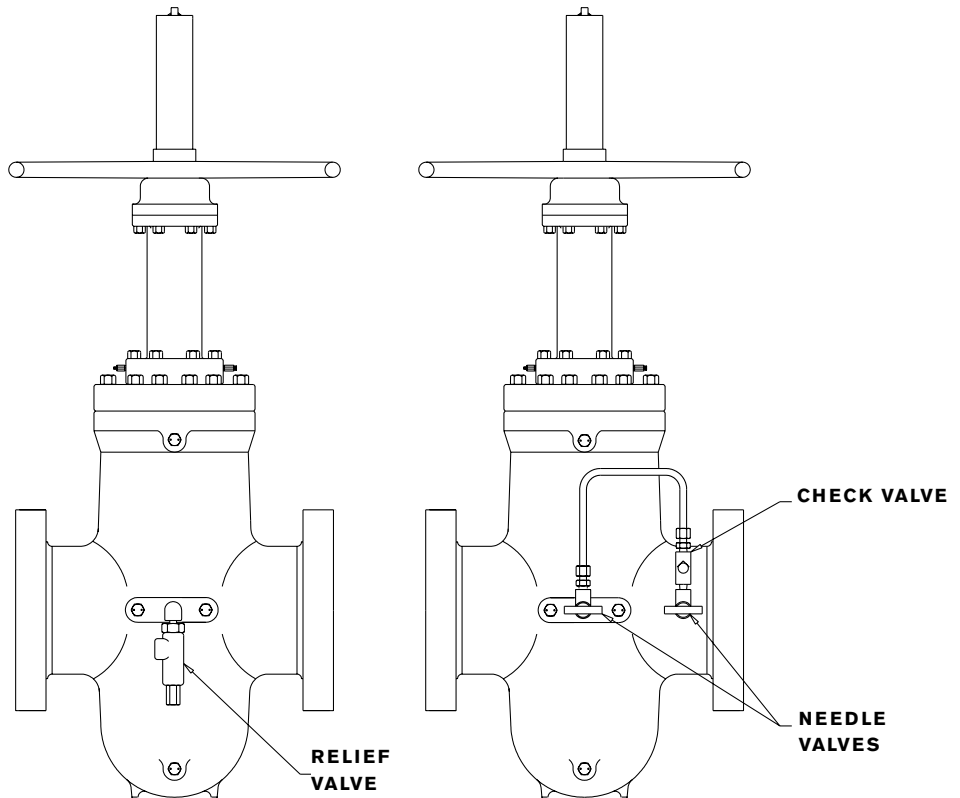

FIG. 3A

FIG. 3B

RECOMMENDED SPARE PARTS

It is recommended that the following spare parts be inventoried in operations having numerous valves of a given size and an in-house maintenance program:

Part Description	Number of Valves to be Supported			
	<10	11-20	21-30	31-40
Gate & Segment Assembly	0	1	2	3
Seat Assembly	0	2	4	6
Stem	0	1	2	3
Bonnet & Yoke Seals	1	2	3	4
Packing Set	1	2	4	6
Gear Box	0	0	1	1
Handwheel	0	1	2	2
Vent/Grease Fitting	2	4	8	12
Injectible Packing (box)	1	2	4	4
Body Relief Valve	1	2	4	6
Packing Injection Fitting	1	2	4	6
Stem Nut Bearings, Set	1	2	2	4

SERVICE

SPX is committed to helping you maximize the performance of your valve solutions throughout their lifetime. SPX provides innovative ways to improve your productivity and profitability. We'll help you minimize your asset investments. While ensuring that you continue to meet your production requirements. Our well trained and experienced staff is available to provide technical advice, backup documentation, spare parts and repair services; in the plant or in the field. We will work with you, from start to finish, to ensure the product you need is the product you get.

Please consult your local M&J representative to take advantage of our team of experts, ready to assist you with your every requirement.

FIRE TEST QUALIFICATIONS

M&J Expanding Gate Valves have been designed to meet the most stringent standards. Part of this is fire testing to the requirements of API-6FA. In addition to the normal in-house testing program, fire tests have been witnessed and certified by independent authorities. Fire test qualified design and certification can be provided, when specified.

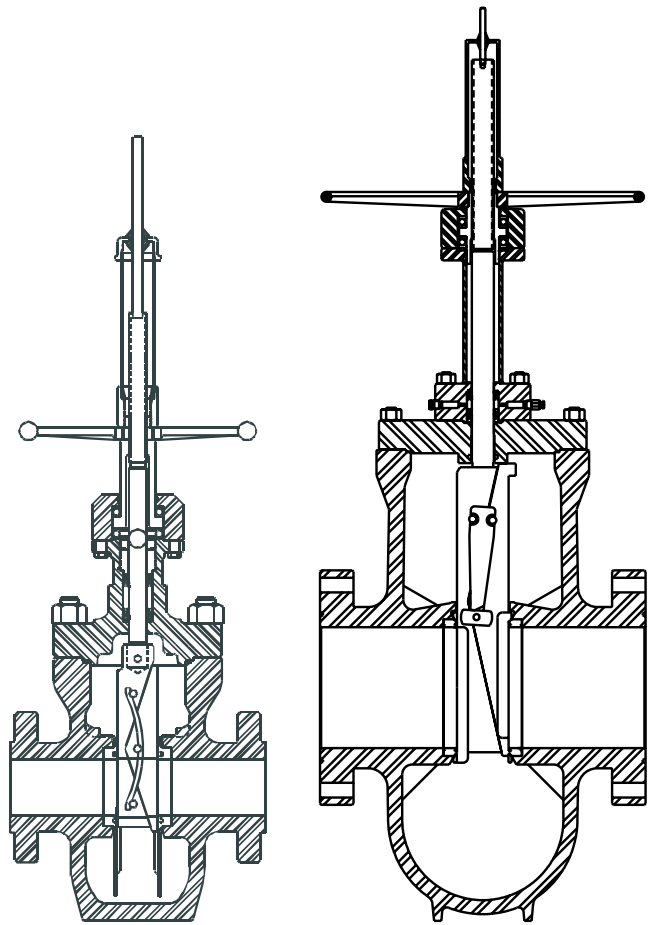

2" - 4"

6" AND LARGER

NAMEPLATE DATA

Nameplates on M&J Expanding Gate Valves provide all of the necessary information to identify the valve when contacting the factory for spares or assistance.

SPX		M&J Valve		
HOUSTON, TEXAS				
PATENTED: 5,163,655 AND 6,164,622				
SIZE	CLASS	MODEL	API 6D	F/F
BODY	GATE	SEAT	STEM	SEAL
TEMP				
MOP				
DATE MFG	LICENSE NO	SERIAL NUMBER		
	6D-0079			

API 6A NON-RISING STEM EXPANDING GATE VALVES

M&J also manufactures Model EG Non-Rising Stem Expanding Gate Valves. These valves are manufactured and tested in accordance with API 6A and are available in 2000 and 3000 psi working pressures.

Standard Product And Available Options

FEATURE		STANDARD (IN / MM)	WHEN SPECIFIED
API-6D/Q1		X	
ISO 9001		X	
HANDWHEEL OPERATOR		2"-12" (50.8-304.8)	
BEVEL GEAR OPERATOR		14" & LGR (355.6 & up)	4"-12" (101.6-304.8)
POWER ACTUATOR			X
DOUBLE BLOCK & BLEED			X
HIDDEN SECONDARY SEALANT CHECK			X
BURIED SERVICE	EXTENDED STEM		X
	EXTENDED SEALANT, VENT & DRAIN		X
LOCKING DEVICE			X
TRANSITION PIECE (PUPS)			X
EMERGENCY PACKING INJECTION		X	
EXTERNAL RELIEF		X	
EXTERNAL PIPING TO UPSTREAM			X
BODY VENT FITTING		X	
BODY DRAIN/INJECTION FITTING		X	
LIFT LUGS	6"-12" (152.4-304.6MM)		X
	14" & UP (101.6MM & UP)	X	
BODY FOOTING		X	
STEM POSITION INDICATOR		X	
OUTSIDE PACKING GLAND		X	
API MONOGRAM		X	
API-6D TEST:	HYDRO-SHELL	X	
	HYDRO-SEAT	X	
	AIR SEAT		X
	OPERATIONAL TORQUE TEST		X
	EXTENDED HYDRO TEST		X
NDE:	VISUAL (API 6D)	X	
	ULTRASONIC		X
	DYE PENETRANT		X
	MAGNETIC PARTICLE		X
	RADIOGRAPHY		X
DOCUMENTATION/CERTIFICATION:	HYDROTEST REPORTS		X
	MATERIAL TEST REPORTS (MTRS)		X
	HYDROTEST CHARTS		X
	NDE REPORTS		X
	NACE		X
	FIRE-TEST CERTIFICATION		X
	CERTIFICATE OF COMPLIANCE		X
	OPERATIONAL TEST REPORTS		X

Exploded View

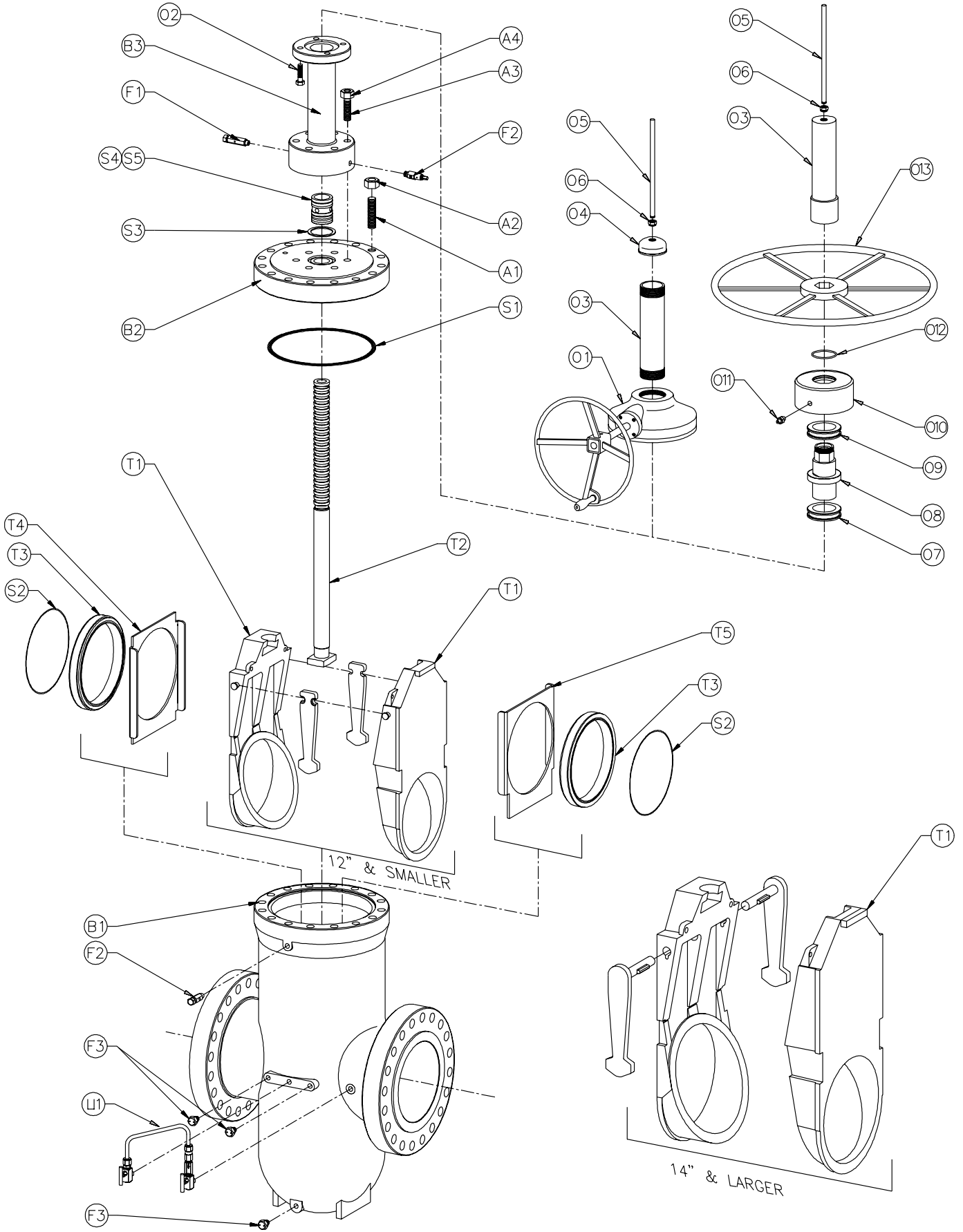

ITEM	DESCRIPTION
A1	Body/Bonnet Studs
A2	Body/Bonnet Nuts
A3	Yoke Tube/Bonnet Studs
A4	Yoke Tube/Bonnet Nuts
B1	Body
B2	Bonnet
B3	Yoke Tube
F1	Packing Fitting
F2	Packing Plug/Vent
F3	Body Vent/Grease Fitting
O1	Operator
O2	Yoke/Operator Cap Screw
O3	Stem Protector
O4	Stem Protector Cap
O5	Indicator Rod
O6	Rod Wiper
O7	Lower Bearing
O8	Stem Nut
O9	Upper Bearing
O10	Bearing Cap
O11	Grease Fitting
O12	Oil Seal
O13	Handwheel
S1	Body/Bonnet Seal
S2	Sediment Seal
S3	Yoke Tube Gasket
S4	Packing Set
S5	Lantern Ring
T1	Gate & Segment
T2	Stem
T3	Seat Assembly
T4	Gate Skirt
T5	Segment Skirt
U1	Upstream Relief

Standard Metallic Trims For Selected Services

T1 - Standard - Carbon Steel - Hydrocarbons
T3 - Full Stainless Steel - Highly Corrosive
T4 - Carbon Steel - NACE
T6 - Carbon Steel - 410SS Internals - NACE
T7 - Brine - Salt - Mildly Corrosive - NACE
T8 - Waterflood - Brine - NACE
S4 - Carbon Steel - NACE - 17-PH Stem
G1 - High Temperature - Geothermal
G2 - High Temperature - Geothermal - HF Gate
L1 - Low Temperature - Carbon Steel
L4 - Low Temperature - NACE Carbon Steel

Note: This is a sample of services and standard trims.

For assistance with a specific service, contact M&J Valve.

Seal Code Definitions

ITEM	DESCRIPTION	RV 0°F to 350°F	GT 0°F to 550°F	LR 0°F to 350°F	GV 0°F to 550°F
S1	Body/Bonnet Seal	18-8SST/Grafoil	18-8SST/Grafoil	18-8SST/Grafoil	18-8SST/Grafoil
S2	Sediment Seal	Viton	EPDM	Viton	Viton
S3	Yoke Tube Gasket	18-8SST/Grafoil	18-8SST/Grafoil	18-8SST/Grafoil	18-8SST/Grafoil
S4	Packing Set	Ryton Filled TFE	40% Glass Filled TFE	Ryton/Viton	Graphoil
S5	Lantern Ring	Not Req'd.	Not Req'd.	AISI 1018/ ENP	AISI 1018/ENP

Figure Number Key

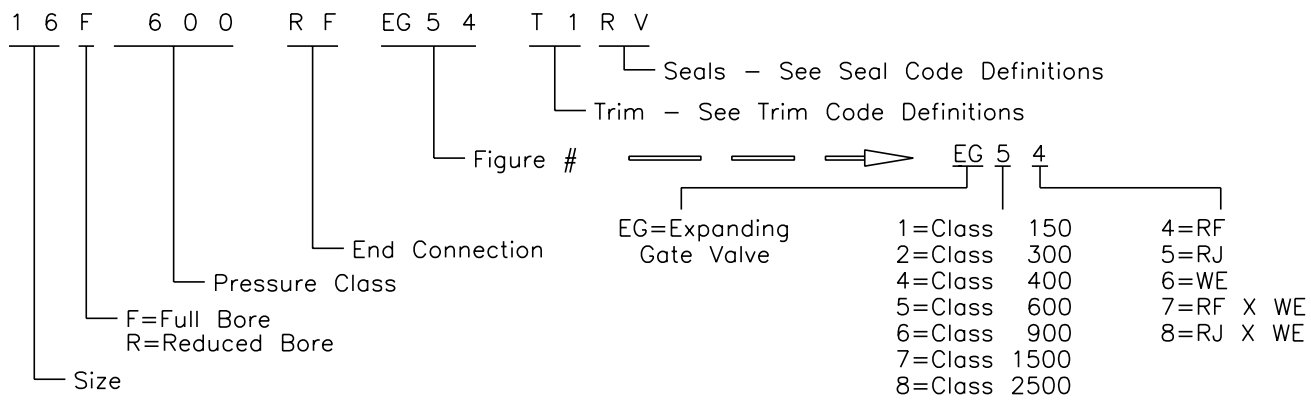

TRIM CODE DEFINITIONS

ITEM	DESCRIPTION	T1	L1	T3	T4	L4	T6	T7	T8	S4	G1	G2
B1	Body	ASTM A216 WCC	ASTM A350 LCC	ASTM A351 CF8M	ASTM A216 WCC	ASTM A350 LCC	ASTM A216 WCC	ASTM A216 WCC/EPOXY COATED	ASTM A216 WCC/EPOXY COATED	ASTM A216 WCC	ASTM A216 WCC	ASTM A216 WCC
B2	Bonnet	ASTM A516 GR. 70	ASTM A537 CL1	AISI 316SS	ASTM A516 GR. 70	ASTM A537 CL1	ASTM A516 GR. 70	ASTM A516 GR. 70/EPOXY COATED	ASTM A516 GR. 70/EPOXY COATED	ASTM A516 GR. 70	ASTM A516 GR. 70	ASTM A516 GR. 70
B3	Yoke Tube	ASTM A516/A36/A53	ASTM A537 CL1/A333	ASTM A516/A36/A53 625 CLAD PKG BOX	ASTM A516/A36/A53	ASTM A537 CL1/A333	ASTM A516/A36/A53	ASTM A516/A36/A53	ASTM A516/A36/A53	ASTM A516/A36/A53	ASTM A516/A36/A53	ASTM A516/A36/A53
T1	Gate & Segment	ASTM A216 GR. WCC/ENP	ASTM A216 GR. WCC/ENP	ASTM A351 CF8M	ASTM A216 GR. WCC/ENP	ASTM A216 GR. WCC/ENP	ASTM A487 GR CA6NM	ASTM A216 GR WCC/ENP	ASTM A747 GR CB7CU-1 (17-4PH)	ASTM A216 GR WCC/ENP	ASTM A216 GR WCC/ENP	ASTM A216 GR WCC/ENP
T2	Stem	AISI 4140/ENP	AISI 4140/ENP	ASTM B630 17-4PH H1150	AISI 4140/ENP	AISI 4140/ENP	AISI 410	AISI 4140/ENP	ASTM B630 17-4PH H1150	ASTM B630 17-4PH H1150	ASTM B630 17-4PH H1150	ASTM B630 17-4PH H1150
T3	Seat Assembly	AISI 1018/ENP/TFE	AISI 1018/ENP/TFE	AISI 316/ HF/TFE	AISI 1018/ENP/TFE	AISI 1018/ENP/TFE	AISI 410/ NITRO H	AISI 1018/ENP/TFE	AISI 316/ HF/TFE	AISI 1018/ENP/TFE	ASTM 1018/ HF-40% GFTFE	ASTM 1018/ HF/40% GFTFE
T4	Gate Skirt	ASTM A36	ASTM A36	AISI 316SS	ASTM A36	ASTM A36	AISI 410	ASTM A36/ENP	ASTM A36/ENP	ASTM A36	ASTM A36	ASTM A36
T5	Segment Skirt	ASTM A36	ASTM A36	AISI 316SS	ASTM A36	ASTM A36	AISI 410	ASTM A36/ENP	ASTM A36/ENP	ASTM A36	ASTM A36	ASTM A36
A1	Body/Bonnet Studs	ASTM A193 B7	ASTM A320 L7	ASTM A193 B7 FLRCTD	ASTM A193 B7M	ASTM A320 L7M	ASTM A193 B7	ASTM A193 B7M	ASTM A193 B7M	ASTM A193 B7M	ASTM A193 B7M	ASTM A193 B7M
A2	Body/Bonnet Nuts	ASTM A194 2H	ASTM A194 GR. 7	ASTM A194 2H FLRCTD	ASTM A194 2HM	ASTM A194 GR. 7M	ASTM A194 2H	ASTM A194 2HM	ASTM A194 2HM	ASTM A194 2HM	ASTM A194 2HM	ASTM A194 2HM
A3	Yoke Tube/ Bonnet Studs	ASTM A193 B7	ASTM A320 L7	ASTM A193 B7 FLRCTD	ASTM A193 B7M	ASTM A320 L7M	ASTM A193 B7	ASTM A193 B7M	ASTM A193 B7M	ASTM A193 B7M	ASTM A193 B7M	ASTM A193 B7M
A4	Yoke Tube/ Bonnet Nuts	ASTM A194 2H	ASTM A194 GR. 7	ASTM A194 2H FLRCTD	ASTM A194 2HM	ASTM A194 GR. 7M	ASTM A194 2H	ASTM A194 2HM	ASTM A194 2HM	ASTM A194 2HM	ASTM A194 2HM	ASTM A194 2HM
F1	Packing Fitting	Steel	18-8 SST	18-8 SST	18-8 SST	18-8 SST	18-8 SST	18-8 SST	18-8 SST	18-8 SST	18-8 SST	18-8 SST
F2	Packing Plug/ Vent	Steel	18-8 SST	18-8 SST	18-8 SST	18-8 SST	18-8 SST	18-8 SST	18-8 SST	18-8 SST	18-8 SST	18-8 SST
F3	Body Vent/Grs Fitting	Steel	18-8 SST	18-8 SST	18-8 SST	18-8 SST	18-8 SST	18-8 SST	18-8 SST	18-8 SST	18-8 SST	18-8 SST

RV - RYTON/VITON

LR - LANTERN RING/Ryton/VITON

GT - GEOTHERMAL/EPR

GV - GRAPHOIL/VITON

Operator Sizing Requirements

2" - 4" CLASSES 600 - 900

6" - 36" CLASSES 300 - 900

SIZE	CLASS	ANSI WORKING PRESSURE		STEM THREAD			RECOMMENDED OPERATING THRUST	RECOMMENDED OPERATING TORQUE		MAXIMUM ALLOWABLE THRUST	MAXIMUM ALLOWABLE TORQUE		TOTAL STEM TRAVEL	TURNS TO OPEN
				SIZE	PITCH	LEAD		FT-LB	N-M		FT-LB	N-M		
IN/MM		PSI/BAR	KG/CM ²	IN/MM	IN/MM	IN/MM	LB /KG			LB/KG			IN/MM	
2 (50)	600	1,500 (103.4)	105	.88 (22.2)	0.167 (4.2)	0.167 (4.2)	2,526 (1,146)	17	23	16,289 (7,388)	108	146	2.75 (69.85)	16.5
	900	2,250 (155.1)	158				3,788 (1,718)	25	34					
4 (100)	600	1,500 (103.4)	105	1.250 (31.7)	0.250 (6.3)	0.250 (6.3)	6,612 (2,999)	63	86	31,868 (14,453)	305	413	4.88 (124)	19.5
	900	2,250 (155.1)	158				9,918 (4,498)	95	129					
6 (150)	300	750 (51.7)	53	1.500 (38.1)	0.286 (7.2)	0.286 (7.2)	6,400 (2,902)	73	99	48,000 (21,769)	546	740	7.06 (179.3)	25
	600	1,500 (103.4)	105				12,800 (5,805)	146	197					
	900	2,250 (155.1)	158				19,199 (8,707)	218	296					
8 (200)	300	750 (51.7)	53	2.000 (50.8)	0.333 (8.4)	0.333 (8.4)	10,994 (4,986)	161	219	94,177 (42,711)	1,380	1,872	9.25 (235)	28
	600	1,500 (103.4)	105				21,987 (9,972)	322	437					
	900	2,250 (155.1)	158				32,981 (14,957)	483	656					
10 (250)	300	750 (51.7)	53	2.250 (57.1)	0.333 (8.4)	0.333 (8.4)	16,126 (7,313)	259	351	127,226 (57,699)	2,041	2,767	11.38 (289)	34
	600	1,500 (103.4)	105				32,251 (14,626)	517	702					
	900	2,250 (155.1)	158				48,377 (21,940)	776	1,052					
12 (300)	300	750 (51.7)	53	2.250 (57.1)	0.333 (8.4)	0.333 (8.4)	21,574 (9,784)	346	469	127,226 (57,699)	2,041	2,767	13.31 (338)	40
	600	1,500 (103.4)	105				43,152 (19,570)	692	939					
	900	2,250 (155.1)	158				64,723 (29,353)	1,038	1,408					
16 (400)	300	750 (51.7)	53	2.500 (63.5)	0.333 (8.4)	0.333 (8.4)	32,444 (14,714)	566	767	168,876 (76,588)	2,944	3,992	16.63 (422.4)	50
	600	1,500 (103.4)	105				64,887 (29,427)	1,131	1,534					
	900	2,250 (155.1)	158				97,331 (44,141)	1,697	2,301					
20 (500)	300	750 (51.7)	53	2.875 (73)	0.400 (10.1)	0.400 (10.1)	50,698 (22,992)	1,027	1,392	220,220 (99,873)	4,460	6,047	22.00 (559)	55
	600	1,500 (103.4)	105				101,396 (45,984)	2,053	2,784					
	900	2,250 (155.1)	158				152,094 (68,977)	3,080	4,177					
22 (550)	600	1,500 (103.4)	105	2.875 (73)	0.400 (10.1)	0.800 (20.3)	142,124 (64,455)	3,866	5,243	199,542 (90,495)	5,429	7,361	24.25 (616)	30.3
24 (600)	300	750 (51.7)	53	2.63 (66.8)	0.333 (8.4)	0.666 (16.9)	30,369 (13,775)	690	935	175,865 (79,771)	3,994	5,415	28.13 (715)	42
	600	1,500 (103.4)	105				151,845 (68,876)	3,449	4,676					
30 (750)	300	750 (51.7)	53	3.13 (79.5)	0.400 (10.1)	0.800 (20.3)	112,888 (51,205)	3,063	4,153	250,000 (113,400)	6,800	9,220	32.88 (835)	41
	600	1,500 (103.4)	105				225,775 (102,410)	6,126	8,306					
	900	2,250 (155.1)	158				405,230 (183,809)	15,173	20,572					
36 (900)	600	1,500 (103.4)	105	4.38 (111.3)	0.500 (12.7)	1.00 (25.4)	368,129 (166,980)	14,349	19,455	550,645 (249,768)	21,463	29,100	38.75 (984.3)	38.8

Notes:

1. Recommended operating thrust and torque values are the loads required to open and close the valve. These torques do not contain service or safety factors.
2. Recommended operating torque and thrust values are based on maximum working pressure at ambient temperature. To obtain expected torques at lower temperatures, contact M&J Valve.
3. Actuator selection should be made based on experience and appropriate service/safety factors.
4. Maximum allowable thrust and torque values are the maximum allowable loads of the valve.

* For sizes/classes not listed, contact M&J Valve for details.

2"- 36" Rising Stem Expanding Gate Valves

PRINCIPAL DIMENSIONS

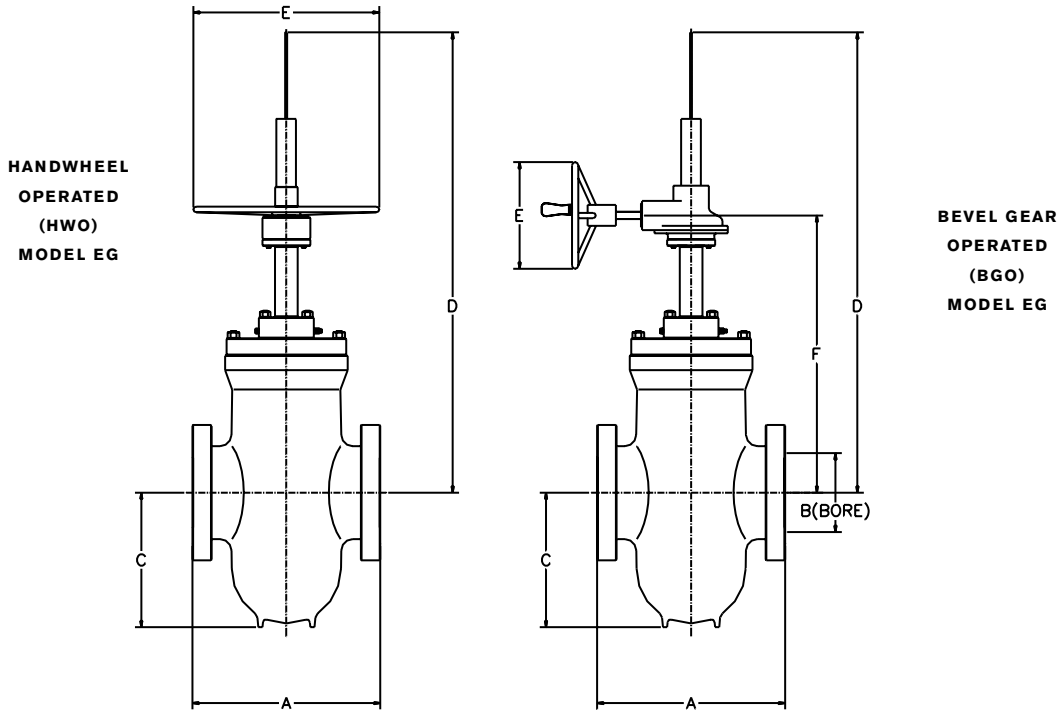

SIZE IN (MM)	CLASS 300									
	A (RJ)	A (RF)	B	C	D (HWO)	D (BGO)	E (HWO)	E (BGO)	F (BGO)	WEIGHT LBS (KGS)
6 (150)	16.50 (419)	15.88 (403)	6 (152)	12.63 (321)	50.25 (1,276)	51.25 (1,302)	18 (457)	18 (457)	29.50 (749)	550 (249)
8 (200)	17.13 (435)	16.50 (419)	8 (203)	15.50 (394)	61 (1,550)	62 (1,575)	26 (660)	24 (610)	35.63 (905)	850 (385)
10 (250)	18.63 (473)	18 (457)	10 (254)	20 (508)	73.25 (1,860)	74.25 (1,886)	32 (813)	24 (610)	43.38 (1,102)	1,250 (567)
12 (300)	30.13* (765)	30* (762)	12 (305)	23 (584)	82.13 (2,086)	85.88 (2,181)	32 (813)	28 (711)	49.25 (1,251)	1,900 (862)
12.375 (314)	30.13* (765)	30* (762)	12.38 (314)	23 (584)	82.13 (2,086)	85.13 (2,162)	32 (813)	28 (711)	49.25 (1,251)	1,900 (862)
12.5 (317)	30.13* (765)	30* (762)	12.50 (318)	23 (584)	82.13 (2,086)	85.13 (2,162)	32 (813)	28 (711)	49.25 (1,251)	1,900 (862)
16 (400)	33.63 (854)	33 (838)	15.25 (387)	28.75 (730)	-	101.25 (2,572)	-	30 (762)	58.50 (1,486)	3,500 (1,587)
20 (500)	41.75* (1,060)	41.5* (1,054)	19.25 (489)	38.5 (978)	-	123.75 (3,143)	-	36 (914)	75 (1,905)	6,500 (2,948)
24 (600)	45.88 (1,165)	45 (1,143)	23.25 (591)	51.5 (1,308)	-	144 (3,658)	-	36 (914)	88 (2,235)	11,500 (5,215)
30 (760)	66 (1,676)	60 (1,651)	29 (737)	60 (1,524)	-	172 (4,369)	-	36 (914)	102 (2,591)	18,500 (8,391)

Inch
(millimeter)

*400 END-TO-END

FLANGE DIMENSIONS CONFORM TO AMERICAN NATIONAL STANDARD INSTITUTE STANDARD B16.5.

OTHER SIZES AND PRESSURES AVAILABLE ON REQUEST.

INFORMATION ON POWER-ACTUATED AND OTHER TYPES AVAILABLE ON APPLICATION.

SIZE IN/MM	CLASS 600									
	A IN//MM	A IN//MM	B IN//MM	C IN//MM	D IN//MM	D IN//MM	E IN//MM	E IN//MM	F IN//MM	WEIGHT LB/KG
DN	(RJ)	(RF)			(HWO)	(BGO)	(HWO)	(BGO)	(BGO)	(LBS.) (KGS.)
2 (50)	11.63 (295)	11.5 (292)	2.06 (52)	5.38 (137)	17.75 (451)	-	12 (305)	-	-	95 (43)
4 (100)	17.13 (435)	17 (432)	4.06 (103)	8.88 (226)	31.25 (794)	-	16 (406)	-	-	350 (159)
6 (150)	22.13 (562)	22 (559)	6 (152)	12.63 (226)	43 (1,092)	44 (1,118)	18 (457)	18 (457)	29.5 (749)	695 (315)
8 (200)	26.13 (664)	26 (660)	8 (203)	15.5 (394)	55 (1,397)	56 (1,422)	26 (660)	24 (610)	35.63 (905)	1,025 (465)
10 (250)	31.13 (791)	31 (787)	10 (254)	19.75 (502)	65 (1,651)	66 (1,676)	32 (813)	24 (610)	43.38 (1,102)	1,750 (794)
12 (300)	33.13 (842)	33 (838)	12 (305)	23 (584)	66.25 (1,683)	70 (1,778)	32 (813)	28 (711)	49.25 (1,251)	2,600 (1,179)
12.975 (315)	33.13 (842)	33 (838)	12.38 (314)	23 (584)	66.25 (1,683)	70 (1,778)	32 (813)	28 (711)	49.25 (1,251)	2,600 (1,179)
12.50 (320)	33.13 (842)	33 (838)	12.5 (318)	23 (584)	66.25 (1,683)	70 (1,778)	32 (813)	28 (711)	49.25 (1,251)	2,600 (1,179)
16 (400)	39.13 (994)	39 (991)	15.25 (387)	28.75 (730)	-	81 (2,057)	-	30 (762)	61.25 (1,556)	4,450 (2,018)
20 (500)	47.25 (1,200)	47 (1,194)	19.25 (489)	38.5 (978)	-	107 (2,718)	-	36 (914)	75 (1,905)	7,400 (3,356)
22 (550)	51.38 (1,305)	51 (1,295)	21.25 (540)	42.25 (1,073)	-	140 (3,556)	-	36 (914)	83.8 (2,129)	11,000 (4,989)
24 (600)	55.38 (1,407)	55 (1,397)	23.25 (591)	51.5 (1,308)	-	144 (3,658)	-	36 (914)	88 (2,235)	12,000 (5,442)
30 (600)	65.50 (1,664)	65 (1,651)	29 (737)	60 (1,524)	-	172 (4,369)	-	36 (914)	102 (2,591)	24,200 (10,997)
36 (900)	82.50 (2,096)	82 (2,083)	35 (889)	68 (1,727)	*	*	*	*	*	35,000 (15,905)

* Contact M&J Valve for details.

SIZE IN/MM	CLASS 900									
	A IN//MM	A IN//MM	B IN//MM	C IN//MM	D IN//MM	D IN//MM	E IN//MM	E IN//MM	F IN//MM	WEIGHT LBS/KG
DN	(RJ)	(RF)			(HWO)	(BGO)	(HWO)	(BGO)	(BGO)	(LBS.) (KGS.)
2 (50)	14.63 (372)	14.5 (368)	2.06 (52)	5.38 (137)	17.75 (451)	-	12 (305)	-	-	145 (66)
4 (100)	18.13 (461)	18 (457)	4.06 (103)	9 (229)	31.25 (794)	-	16 (406)	-	-	510 (231)
6 (150)	24.13 (613)	24 (610)	6 (152)	12.81 (325)	45 (1,143)	46 (1,168)	18 (457)	18 (457)	29.5 (749)	860 (390)
8 (200)	29.13 (740)	29 (737)	8 (203)	15.75 (400)	55 (1,397)	56 (1,422)	26 (660)	24 (610)	35.63 (905)	1,270 (576)
10 (250)	33.13 (842)	33 (838)	10 (254)	20 (508)	65 (1,651)	66 (1,676)	32 (813)	24 (610)	43.63 (1,108)	2,300 (1,043)
12 (300)	38.13 (969)	38 (965)	12 (305)	23.5 (597)	66.25 (1,683)	66 (1,676)	32 (813)	30 (762)	49.25 (1,251)	3,500 (1,587)
12.374 (315)	38.13 (969)	38 (965)	12.38 (314)	23.5 (597)	66.25 (1,683)	70 (1,778)	32 (813)	30 (762)	49.25 (1,251)	3,500 (1,587)
12.5 (320)	38.13 (969)	38 (965)	12.5 (318)	23.5 (597)	66.25 (1,683)	70 (1,778)	32 (813)	30 (762)	49.25 (1,251)	3,500 (1,587)
16 (400)	44.88 (1,140)	44.5 (1,130)	14.75 (375)	30.25 (768)	-	81 (2,057)	-	30 (762)	66.5 (1,689)	7,300 (3,311)
20 (500)	52.5 (1,334)	52 (1,321)	18.63 (473)	51.5 (1,118)	-	107 (2,718)	-	36 (914)	75 (1,905)	9,200 (4,172)
30 (750)	85.50 (2,172)	85 (2,159)	28.50 (724)	57.75 (1,467)	-	-	-	-	-	37,000 (16,783)

Yoke Tube Flange Dimensions

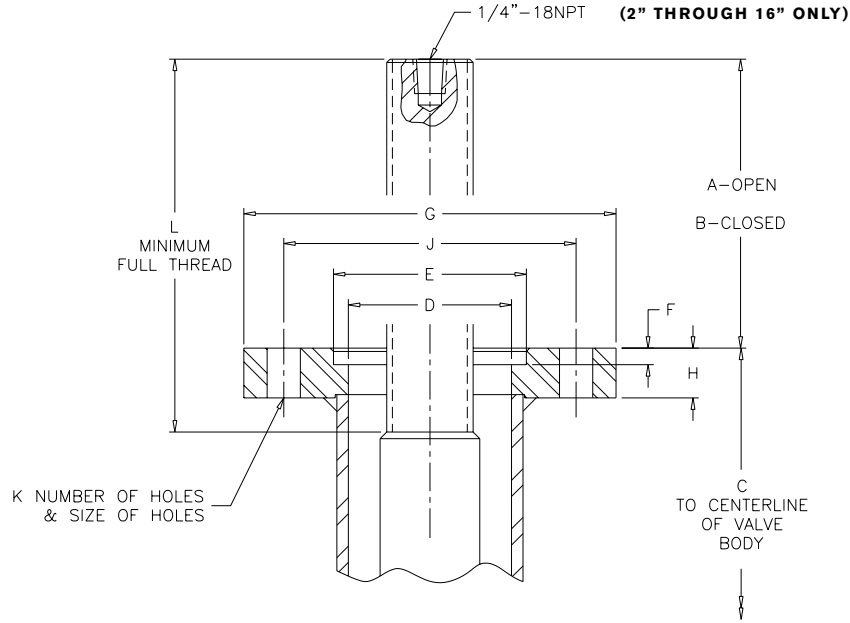

SIZE IN (MM)	CLASS	A	B	C	D	E	F	G	H	J	K	L
		IN/MM	IN/MM	IN/MM	IN/MM	IN/MM	IN/MM	IN/MM	IN/MM	IN/MM		
4 (100)	300-900	9.63 (244.6)	4.76 (120.9)	20.13 (511.3)	1.50 (38.1)	2.313 (58.8)	.19 (4.8)	5.00 (127)	0.63 (16.0)	4.00 (101.6)	(4) .44 DIA. STRADDLE CL (11.1)	10 (254)
						2.318 (58.9)						
6 (150)	300-900	11.31 (287.2)	4.25 (107.9)	26.31 (668.2)	2.56 (65)	3.765 (95.6)	.19 (4.8)	8.50 (215.9)	1.25 (31.7)	*5.50 (139.7)	(4) .69 DIA. STRADDLE CL (17.5)	11 (279.4)
						3.775 (95.8)				*6.50 (165.1)		
8 (200)	300-900	15.13 (384.3)	5.88 (149.3)	32.13 (816.1)	3.38 (85.8)	3.765 (95.6)	.19 (4.8)	8.50 (215.9)	1.25 (31.7)	*5.50 (139.7)	(4) .69 DIA. STRADDLE CL (17.5)	15 (381)
						3.775 (95.8)				*6.50 (165.1)		
10 (250)	300-900	17.56 (446)	6.19 (157.2)	39.75 (1,009.6)	3.38 (85.8)	3.765 (95.6)	.19 (4.8)	8.50 (215.9)	1.25 (31.7)	*5.50 (139.7)	(4) .69 DIA. STRADDLE CL (17.5)	17.50 (444.5)
						3.775 (95.8)				*6.50 (165.1)		
12 (300)	300-900	19.50 (495.3)	6.19 (157.2)	44.75 (1,136.6)	3.38 (85.8)	5.015 (127.3)	.25 (6.3)	8.50 (215.9)	1.25 (31.7)	6.50 (165.1)	(4) .81 DIA. STRADDLE CL (20.5)	19.50 (495.3)
						5.025 (127.6)						
16 (400)	300-900	22.75 (577.8)	6.13 (155.7)	56.75 (1,441.4)	3.50 (88.9)	5.015 (127.3)	.25 (6.3)	8.31 (211)	1.50 (38.1)	6.50 (165.1)	(4) .81 DIA. STRADDLE CL (20.5)	24 (609.6)
						5.025 (127.6)						
20 (500)	300-900	30.63 (778)	8.63 (219.2)	65.50 (1,663.7)	6.06 (153.9)	7.005 (177.9)	.31 (7.8)	13.50 (342.9)	2.63 (66.8)	11.75 (298.4)	(8) .88 DIA. STRADDLE CL (22.3)	31.25 (793.7)
						7.010 (178)						
22 (550)	300-900	34.67 (880.6)	10.00 (254.0)	76.26 (1,937.0)	6.06 (153.9)	7.005 (177.9)	.31 (7.8)	13.50 (342.9)	2.63 (66.8)	11.75 (298.4)	(8) .88 DIA. STRADDLE CL (22.3)	34.93 (887.2)
						7.010 (178)						
24 (600)	300-600	38.06 (966.7)	9.94 (252.4)	81.00 (2,057.4)	5.04 (128)	7.005 (177.9)	.31 (7.8)	13.50 (342.9)	1.63 (41.4)	11.75 (298.4)	(8) .88 DIA. STRADDLE CL (22.3)	37.5 (952.5)
						7.010 (178)						
30 (750)	300-600	43.38 (1,101.8)	10.50 (266.7)	93.13 (2,365.5)	6.06 (153.9)	8.505 (216)	.31 (7.8)	16.75 (425.4)	2.63 (66.8)	14.0 (355.6)	(8) 1.38 DIA STRADDLE CL (35)	43.5 (1,104.9)
						8.510 (216.1)						
36 (900)	300-600	48.62 (1,234.9)	11.92 (302.8)	115.13 (2,924.3)	7.98 (202.7)	9.005 (228.7)	.75 (19.1)	18.75 (476.3)	2.63 (66.8)	16.0 (406.4)	(8) 1.38 DIA STRADDLE CL (35)	48.75 (1,238.3)
						9.010 (228.9)						

* Contact M&J Valve for details.

Notes:



ABOUT SPX

Based in Charlotte, North Carolina, SPX Corporation (NYSE: SPW) is a global multi-industry manufacturing leader. For more information, please visit www.spx.com.

SPX FLOW TECHNOLOGY

8800 Westplain Drive
Houston, TX 77041
P: (800) 231-3690 or (281)469-0550
F: (281) 894-1332
E: mjvalve@spx.com

SPX reserves the right to incorporate our latest design and material changes without notice or obligation.

Design features, materials of construction and dimensional data, as described in this bulletin, are provided for your information only and should not be relied upon unless confirmed in writing. Please contact your local sales representative for product availability in your region. For more information visit www.spx.com.

The green ">" is a trademark of SPX Corporation, Inc.