

# Swallowglide

## SINGLE STAGE SOLIDS HANDLING END SUCTION PUMP

### PUMP OVERVIEW

The ClydeUnion Pumps Swallowglide ranges are solids handling end suction pumps, specifically designed for sewage, screened sewage and effluent. Robust design and features developed over years of running experience make the ClydeUnion Pumps Swallowglide a highly reliable pump with hundreds of installations globally.

The latest modular range was designed for optimum efficiency with multi-blade impellers suitable for screened sewage and downstream effluents and sludges.

### TYPICAL APPLICATIONS

- Screened sewage
- Sewage sludge
- Storm water
- Industrial effluents
- Sludges up to 5% solid content



### TECHNICAL DATA

**Capacity:** up to 30,000 m<sup>3</sup>/hr / 130,000 USgpm

**Delivery head:** up to 130 m / 430 ft

**Temperature:** up to 80 °C / 180 °F

**Speeds:** up to 1,500 rpm

**Flange drilling:** ANSI or BS

## FEATURES + BENEFITS

- 1 **Low energy costs**  
Hydraulic design provides high efficiency, low NPSH and stable characteristics. Casing incorporates large passageways to maximise solids handling
- 2 **Optimum seal performance**  
Single, double and cartridge options. Packed gland available on request
- 3 **Ease of maintenance**  
Back pull-out design allows full access without disturbing site pipework or driver
- 4 **Enhanced performance**  
Impellers designed for high efficiency and solids handling. Open-type impellers available on the engineered range. Back blades on impellers prevent build-up of solids at rear of impeller
- 5 **Wear options**  
Casing wear rings fitted as standard, impeller wear ring option available
- 6 **Modular design**  
Minimises spares holding of back pull-out components
- 7 **Simplified build procedures**  
Spigot design facilitates self setting axial clearance

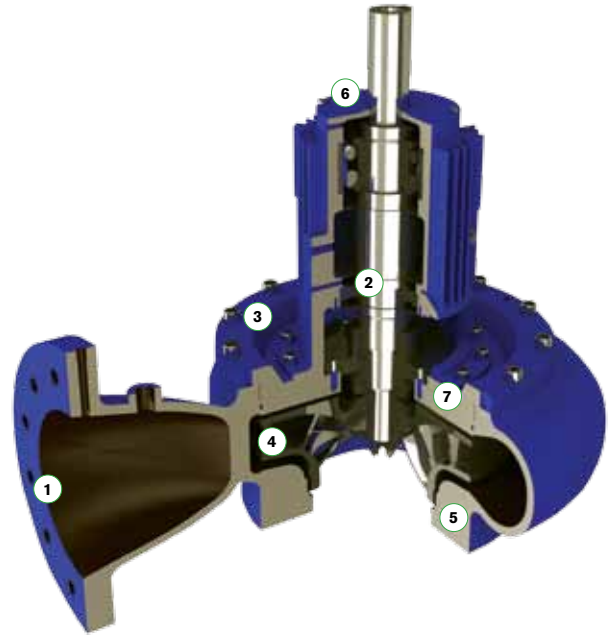

## RANGE COVERAGE CHARTS

50HZ RANGE CHART

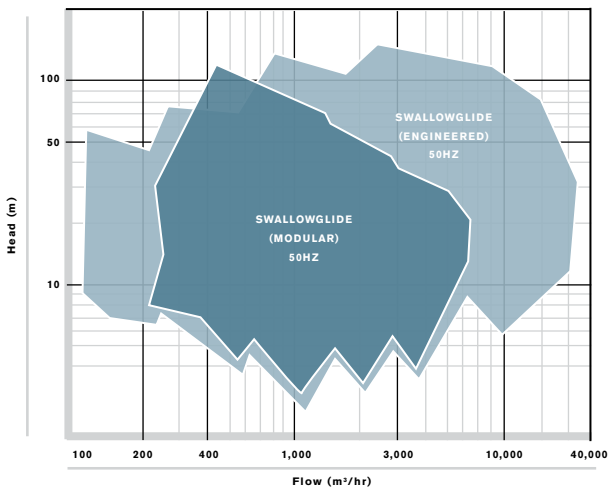

60HZ RANGE CHART

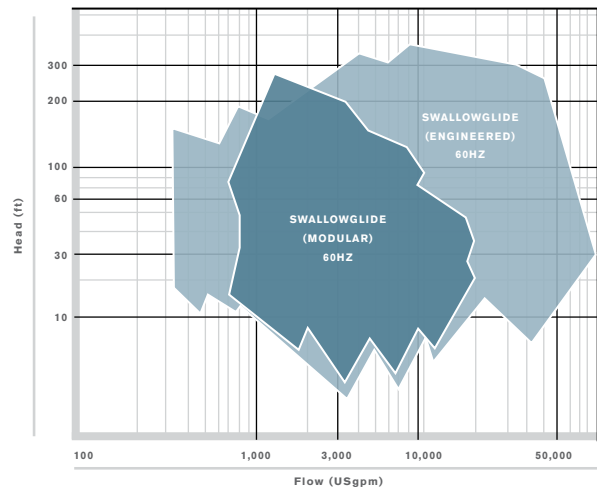

These charts cover the standard pump range. Other engineering designs exist for extreme applications

**SPX**

P: +44 (0)141 637 7141 F: +44 (0)141 633 2399 E: cu.sales@spx.com

For more information about our worldwide locations, approvals, certifications, and local representatives, please visit [www.spx.com](http://www.spx.com).

SPX Corporation reserves the right to incorporate our latest design and material changes without notice or obligation. Design features, materials of construction and dimensional data, as described in this bulletin, are provided for your information only and should not be relied upon unless confirmed in writing.

CUP-04-SWAL-UK-02

COPYRIGHT © 2012 SPX Corporation